

# Distributed and Operating Systems Spring 2025

Prashant Shenoy

UMass CICS

<http://lass.cs.umass.edu/~shenoy/courses/677>

## Module 1: Course Syllabus

- COMPSCI 677: Distributed and Operating Systems
- *Course web page:* <http://lass.cs.umass.edu/~shenoy/courses/677>
  - Syllabus posted on the course web page.
- Class has three sections
  - Section 1 (classroom section)
  - Section 2 (online section)
  - UWW section (online section)
  - All 3 sections do the same work (exams, lab, homework, etc)

# Course Staff

- *Instructor:* Prashant Shenoy
  - Email: [shenoy@umass.edu](mailto:shenoy@umass.edu), Phone: (413) 577 0850
  - Office hours: W: 4-5pm LGRC A333 (also over zoom)
- *Teaching Assistants*

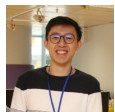

Nathan  
Kwan-Ho Ng

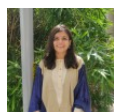

Hetvi  
Shastri



Tammy  
Sukprasert



Bhawana  
Chhagani



Bin  
Wang



David  
Thibideu

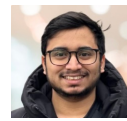

Krishna  
Gudipaty

TA Office Hours: will be posted soon

- *Course/Grading Assistants:* Manish, Simran, Niti, Shruitya, Akhil, Sai, Vaishnavi, Shreya

# Course Textbook

- *Textbook:*
- Distributed Systems, 4th ed, by Tannenbaum and Van Steen, 2023
  - PDF version of this text is available for free from authors
- Distributed Systems, Older 2nd Edition, is also available as a PDF for free from authors
- Distributed and Operating Systems Readings and Course Notes
- **All Download links on Course Materials section of Course website**

# Course Outline

- Introduction (*today*)
  - What, why, why not?
  - Basics
- Distributed Architectures
- Interprocess Communication
  - RPCs, RMI, message- and stream-oriented communication
- Processes and their scheduling
  - Thread/process scheduling, code/process migration, virtualization
- Naming and location management
  - Entities, addresses, access points

# Course Outline

- Canonical problems and solutions
  - Mutual exclusion, leader election, clock synchronization, ...
- Resource sharing, replication and consistency
  - DFS, consistency issues, caching and replication
- Fault-tolerance
- Security in distributed Systems
- Distributed middleware
- Advanced topics: web computing, cloud computing, edge computing, sustainable computing, big data, multimedia, and Internet of Things (IoT)

# Course Grading

- *Grading*
  - 2 exams: one midterm and one final (**44%**)
  - 3 programming labs (**43%**),
  - Assignments (tablets and homework problem sets) (**12%**)
  - class participation/quizzes/piazza discussions: (**1%**)
- *Pre-requisites*
  - Undergrad course in operating systems
  - Good programming skills in a high-level prog. language

# Course Tools

- *Piazza* : online discussion forum.
  - <https://piazza.com/umass/spring2025/compsci677>
- *Gradescope*: Used for assignments and exams
- *Github Classroom* : Used for labs
- We have enrolled you on piazza, gradescope and GitHub classroom!
- *Web page*: <https://lass.cs.umass.edu/~shenoy/courses/677>
- *Youtube Channel*: <https://youtube.com/umassos>
- *Canvas*: Mostly used as an online grade book

# Course Policies

- Class Participation: Need a scribe for each class (*participation points available*)

- Device Policy:



# Module 2: Why Distributed Systems?

- Many systems that we use on a daily basis are distributed
  - World wide web, Google
  - Cloud computing, e.g., Amazon.com
  - Peer-to-peer file sharing systems
  - SETI@Home
  - Grid and cluster computing
  - Modern networked computers
- Useful to understand how such real-world systems work
- Course covers basic principles for designing distributed systems

# Definition of a Distributed System

- **Networked** system - Multiple computers connected over a network
- **Distributed** system - A networked system of independent computers that appears to its users as a single coherent system
- Examples: parallel machines, networked machines
- **Decentralized** system - networked system where processes and resources are *necessarily* spread across multiple computers
- **Distributed** system - networked system where processes and resources are *sufficiently* spread across multiple computers

# Advantages and Disadvantages

- **Advantages**
  - Communication and resource sharing possible
  - Economics – price-performance ratio
  - Reliability, scalability
  - Potential for incremental growth
- **Disadvantages**
  - Distribution-aware PLs, OSs and applications
  - Network connectivity essential
  - Security and privacy

# Transparency in a Distributed System

Transparency	Description
Access	Hide differences in data representation and how a resource is accessed
Location	Hide where a resource is located
Migration	Hide that a resource may move to another location
Relocation	Hide that a resource may be moved to another location while in use
Replication	Hide that a resource may be replicated
Concurrency	Hide that a resource may be shared by several competitive users
Failure	Hide the failure and recovery of a resource
Persistence	Hide whether a (software) resource is in memory or on disk

Different forms of transparency in a distributed system.

# Open Distributed Systems

- Offer services that are described a priori
  - Syntax and semantics are known via protocols
- Services specified via interfaces
- Benefits
  - Interoperability
  - Portability
- Extensibility
  - Open system evolve over time and should be extensible to accommodate new functionality.
  - Separate policy from mechanism

# Scalability Problems

Concept	Example
Centralized services	A single server for all users
Centralized data	A single on-line telephone book
Centralized algorithms	Doing routing based on complete information

Examples of scalability limitations.

# Scaling Techniques

- **Principles** for good decentralized algorithms
  - No machine has complete state
  - Make decision based on local information
  - A single failure does not bring down the system
  - No global clock
- **Techniques**
  - Asynchronous communication
  - Distribution
  - Caching and replication



## Module 3: Distributed Systems History and OS Models

- **Minicomputer** model (e.g., early networks)
  - Each user has local machine
  - Local processing but can fetch remote data (files, databases)
- **Workstation** model (e.g., Sprite)
  - Processing can also migrate
- **Client-server Model** (e.g., V system, world wide web)
  - User has local workstation
  - Powerful workstations serve as servers (file, print, DB servers)
- **Processor pool model** (e.g., Amoeba, Plan 9)
  - Terminals are Xterms or diskless terminals
  - Pool of backend processors handle processing

## Distributed System Models (contd)

- **Cluster** computing systems / Data centers
  - LAN with a cluster of servers + storage
    - Linux, Mosix, ..
    - Used by distributed web servers, scientific applications, enterprise applications
- **Grid** computing systems
  - Cluster of machines connected over a WAN
  - SETI @ home
- **WAN-based clusters** / distributed data centers
  - Google, Amazon, ...
- **Virtualization and data center**
- **Cloud Computing**

# Emerging Models

- Distributed **Pervasive** Systems (aka ubiquitous computing systems)
  - “smaller” nodes with networking capabilities
    - Computing is “everywhere”
  - Home networks: TiVO, Windows Media Center, ...
  - Mobile computing: smart phones, iPADS, Car-based PCs
  - Sensor networks
  - Health-care: personal area networks
- Sustainability as a design goal

# Uniprocessor Operating Systems

- An OS acts as a resource manager or an arbitrator- manages CPU, I/O devices, memory
- OS provides a virtual interface that is easier to use than hardware
- Structure of uniprocessor operating systems
  - **Monolithic** (e.g., MS-DOS, early UNIX)
    - One large kernel that handles everything
  - **Layered** design
    - Functionality is decomposed into N layers
    - Each layer uses services of layer N-1 and implements new service(s) for layer N+1

# Microkernel Operating Systems

Microkernel architecture

- Small kernel
- user-level servers implement additional functionality

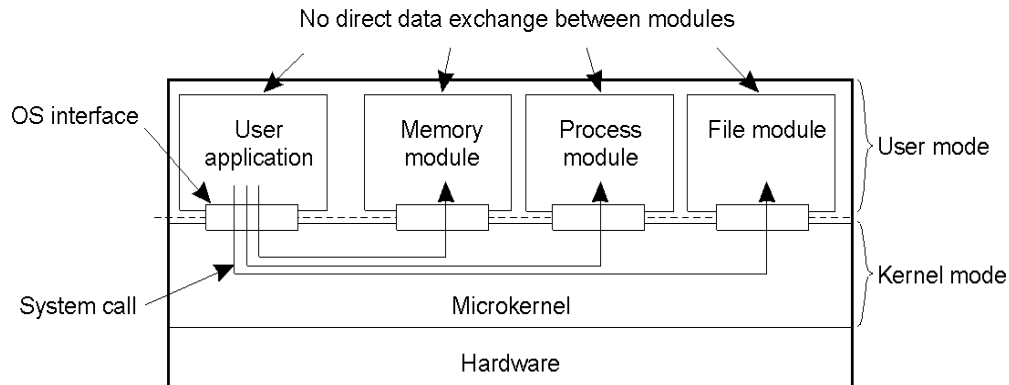

# Distributed Operating System

- Manages resources in a distributed system
  - Seamlessly and transparently to the user
- Looks to the user like a centralized OS
  - But operates on multiple independent CPUs
- Provides transparency
  - Location, migration, concurrency, replication,...
- Presents users with a virtual uniprocessor

# Types of Distributed OSs

System	Description	Main Goal
DOS	Tightly-coupled operating system for multi-processors and homogeneous multicomputers	Hide and manage hardware resources
NOS	Loosely-coupled operating system for heterogeneous multicomputers (LAN and WAN)	Offer local services to remote clients
Middleware	Additional layer atop of NOS implementing general-purpose services	Provide distribution transparency

# Multiprocessor Operating Systems

- Like a uniprocessor operating system
- Manages multiple CPUs transparently to the user
- Each processor has its own hardware cache
  - Maintain consistency of cached data

# Multicomputer Operating Systems

Example: MOSIX cluster - single system image

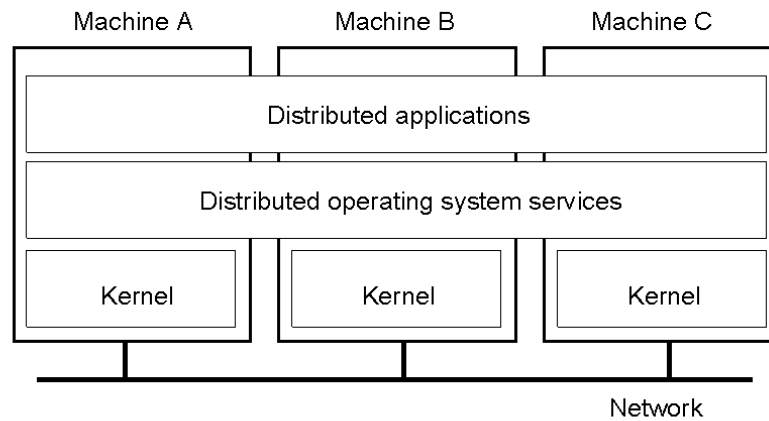

# Network Operating System

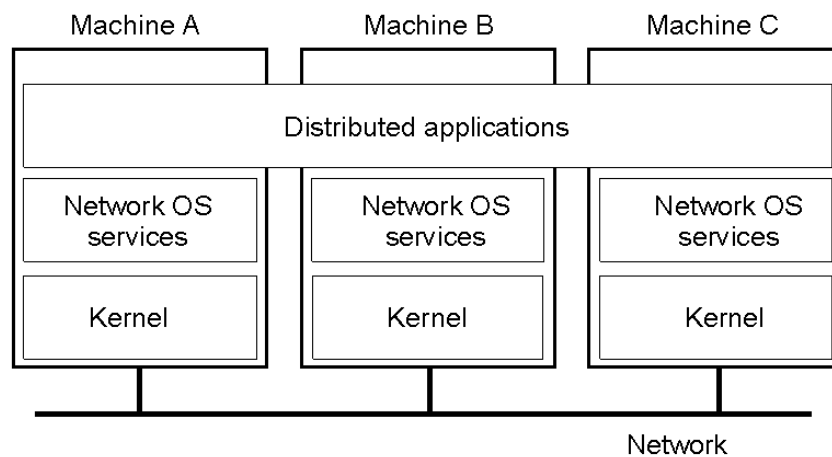

# Network Operating System

- Employs a client-server model
  - Minimal OS kernel
  - Additional functionality as user processes

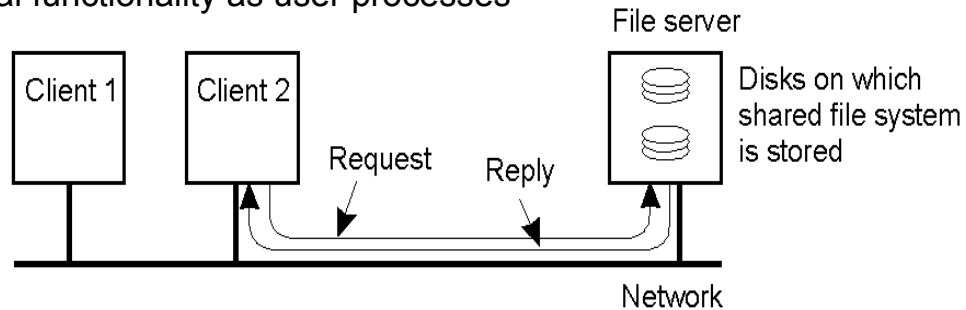

# Middleware-based Systems

- General structure of a distributed system as middleware.

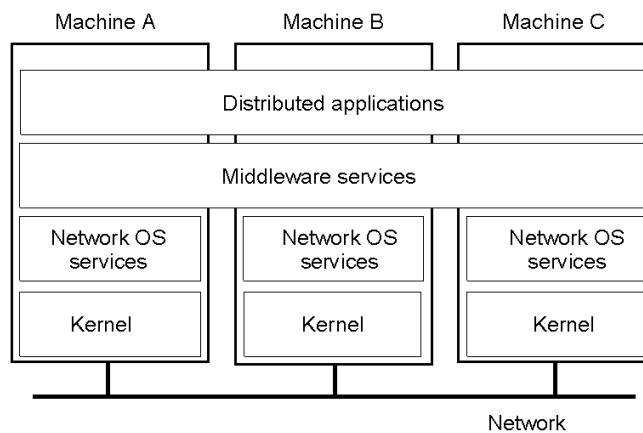

# Comparison between Systems

Item	Distributed OS		Network OS	Middleware-based OS
	Multiproc.	Multicomp.		
Degree of transparency	Very High	High	Low	High
Same OS on all nodes	Yes	Yes	No	No
Number of copies of OS	1	N	N	N
Basis for communication	Shared memory	Messages	Files	Model specific
Resource management	Global, central	Global, distributed	Per node	Per node
Scalability	No	Moderately	Yes	Varies
Openness	Depends on OS	Depends on OS	Open	Open