

Fault Tolerance

- Part 1: Agreement in presence of faults
 - Two army problem
 - Byzantine generals problem
- Part 2: Reliable communication
- Part 3: Distributed commit
 - Two phase commit
 - Three phase commit
- Next class:
 - Paxos and RAFT
 - Failure recovery
 - Checkpointing
 - Message logging

Fault Tolerance

- Single machine systems
 - Failures are all or nothing
 - OS crash, disk failures
- Distributed systems: multiple independent nodes
 - Partial failures are also possible (some nodes fail)
- *Question*: Can we automatically recover from partial failures?
 - Important issue since probability of failure grows with number of independent components (nodes) in the systems
 - $\text{Prob}(\text{failure}) = \text{Prob}(\text{Any one component fails}) = 1 - \text{P}(\text{no failure})$

A Perspective

- Computing systems are not very reliable
 - OS crashes frequently (Windows), buggy software, unreliable hardware, software/hardware incompatibilities
 - Until recently: computer users were “tech savvy”
 - Could depend on users to reboot, troubleshoot problems
 - Growing popularity of Internet/World Wide Web
 - “Novice” users
 - Need to build more reliable/dependable systems
 - Example: what is your TV (or car) broke down every day?
 - Users don't want to “restart” TV or fix it (by opening it up)
- Need to make computing systems more reliable
 - Important for online banking, e-commerce, online trading, webmail...

Basic Concepts

- Need to build *dependable* systems
- Requirements for dependable systems
 - Availability: system should be available for use at any given time
 - 99.999 % availability (five 9s) => very small down times
 - 5 9s: 5.26min downtime/yr. 4 9s: 52.56 min/yr, 3 9s: 8.76 hr/yr, 2 9s: 3.65 days/yr
 - Reliability: system should run continuously without failure
 - Safety: temporary failures should not result in a catastrophic
 - Example: computing systems controlling an airplane, nuclear reactor
 - Maintainability: a failed system should be easy to repair

Basic Concepts (contd)

- Fault tolerance: system should provide services despite faults
 - Transient faults
 - Intermittent faults
 - Permanent faults

Failure Models

Type of failure	Description
Crash failure	A server halts, but is working correctly until it halts
Omission failure <i>Receive omission</i> <i>Send omission</i>	A server fails to respond to incoming requests A server fails to receive incoming messages A server fails to send messages
Timing failure	A server's response lies outside the specified time interval
Response failure <i>Value failure</i> <i>State transition failure</i>	The server's response is incorrect The value of the response is wrong The server deviates from the correct flow of control
Arbitrary failure	A server may produce arbitrary responses at arbitrary times

- Different types of permanent faults.

Failure Masking by Redundancy

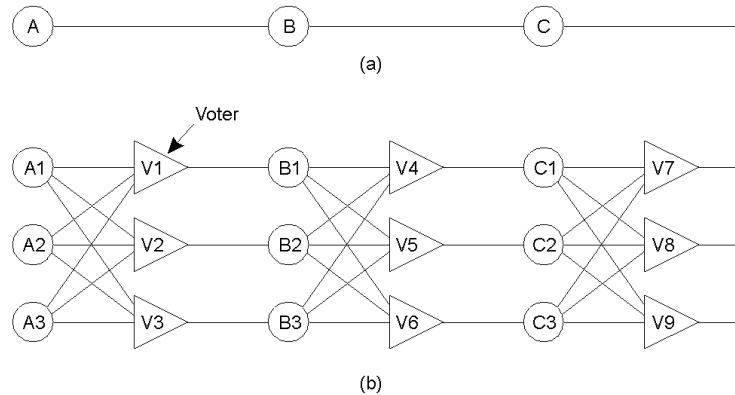

- Triple modular redundancy: can handle one failure in circuit

Agreement in Faulty Systems

- How should processes agree on results of a computation?
- *K-fault tolerant*: system can survive k faults and yet function
- Assume processes fail silently
 - Need $(k+1)$ redundancy to tolerant k faults
- *Byzantine failures*: processes run even if sick
 - Produce erroneous, random or malicious replies
 - Byzantine failures are most difficult to deal with
 - Need ? Redundancy to handle Byzantine faults

Byzantine Faults

- Simplified scenario: two perfect processes with unreliable channel
 - Need to reach agreement on a 1 bit message
- **Two Generals Problem:** Two armies waiting to attack
 - Each army coordinates with a messenger
 - Messenger can be captured by the hostile army
 - Can generals reach agreement?
 - Property: Two perfect process can never reach agreement in presence of unreliable channel
 - Concept of **Common knowledge**
- **Byzantine generals problem:** Can N generals reach agreement with a perfect channel?
 - M generals out of N may be traitors

Byzantine Generals Problem

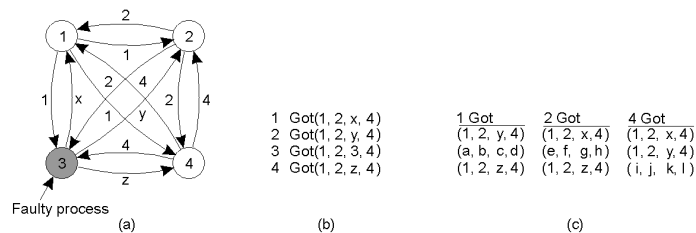

- Recursive algorithm by Lamport
 - The Byzantine generals problem for 3 loyal generals and 1 traitor.
- The generals announce their troop strengths (in units of 1 kilosoldiers).
 - The vectors that each general assembles based on (a)
 - The vectors that each general receives in step 3.

Byzantine Generals Problem Example

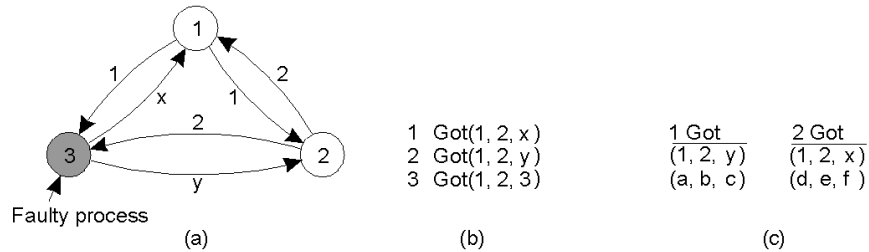

- The same as in previous slide, except now with 2 loyal generals and one traitor.
- Property: With m faulty processes, agreement is possible only if $2m+1$ processes function correctly out of $3m+1$ total processes. [Lamport 82]
 - Need more than two-thirds processes to function correctly (for $m=1$, 3 out of 4 processes)

Byzantine Fault Tolerance

- Detecting a faulty process is easier
 - $2k+1$ to detect k faults
- Reaching agreement is harder
 - Need $3k+1$ processes ($2/3^{\text{rd}}$ majority needed to eliminate the faulty processes)
- Implications on real systems:
 - How many replicas?
 - Separating agreement from execution provides savings

Reaching Agreement

- If message delivery is unbounded,
 - No agreement can be reached even if one process fails
 - Slow process indistinguishable from a faulty one
- BAR Fault Tolerance
 - Until now: nodes are byzantine or collaborative
 - New model: Byzantine, Altruistic and Rational
 - Rational nodes: report timeouts etc

Reliable One-One Communication

- Issues were discussed in Lecture 3
 - Use reliable transport protocols (TCP) or handle at the application layer
- RPC semantics in the presence of failures
- Possibilities
 - Client unable to locate server
 - Lost request messages
 - Server crashes after receiving request
 - Lost reply messages
 - Client crashes after sending request

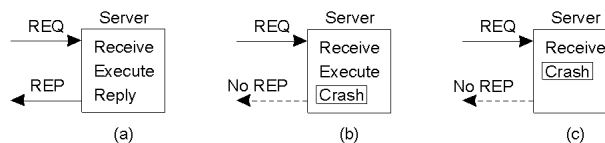

Reliable One-Many Communication

- Reliable multicast
 - Lost messages => need to retransmit
- Possibilities
 - ACK-based schemes
 - Sender can become bottleneck
 - NACK-based schemes

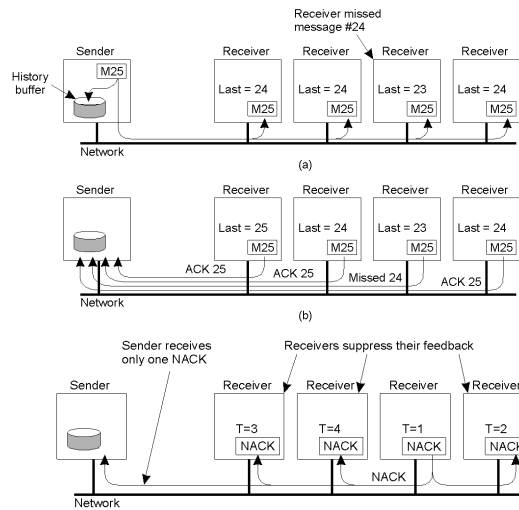

Broadcast Ordering

- Broadcast (or multicast) order important for replication
- FIFO broadcast: if a process sends m1 and then m2, all other processes receive m1 before m2
- Totally ordered: If a process receives m1 before m2 (regardless of sender), all processes receive m1 before m2
 - Does not imply FIFO, all processes just agree on order
- Causally ordered: if $\text{send}(m1) \rightarrow \text{send}(m2) \Rightarrow \text{recv}(m1) \rightarrow \text{recv}(m2)$
- **State machine replication (SMR)**
 - Broadcast requests to all replicas using totally ordered broadcast; replicas apply requests in order.

Atomic Multicast

• Atomic multicast: a guarantee that all process received the message or none at all

- Replicated database example
- Need to detect which updates have been missed by a faulty process

• Problem: how to handle process crashes?

• Solution: *group view*

- Each message is uniquely associated with a group of processes
 - View of the process group when message was sent
 - All processes in the group should have the same view (and agree on it)

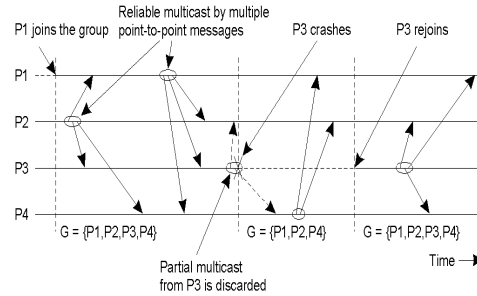

Virtually Synchronous Multicast

Implementing Virtual Synchrony in Isis

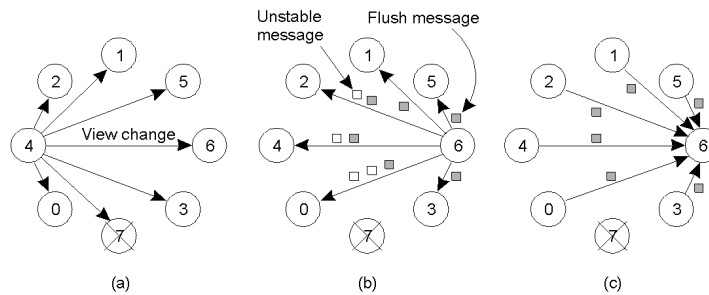

- Process 4 notices that process 7 has crashed, sends a view change
- Process 6 sends out all its unstable messages, followed by a flush message
- Process 6 installs the new view when it has received a flush message from everyone else

Implementing Virtual Synchrony

Multicast	Basic Message Ordering	Total-Ordered Delivery?
Reliable multicast	None	No
FIFO multicast	FIFO-ordered delivery	No
Causal multicast	Causal-ordered delivery	No
Atomic multicast	None	Yes
FIFO atomic multicast	FIFO-ordered delivery	Yes
Causal atomic multicast	Causal-ordered delivery	Yes

Distributed Commit

- Atomic multicast example of a more general problem
 - All processes in a group perform an operation or not at all
 - Examples:
 - Reliable multicast: Operation = delivery of a message
 - Distributed transaction: Operation = commit transaction
- Problem of distributed commit
 - All or nothing operations in a group of processes
- Possible approaches
 - Two phase commit (2PC) [Gray 1978]
 - Three phase commit

Two Phase Commit

- Coordinator process coordinates the operation
- Involves two phases
 - Voting phase: processes vote on whether to commit
 - Decision phase: actually commit or abort

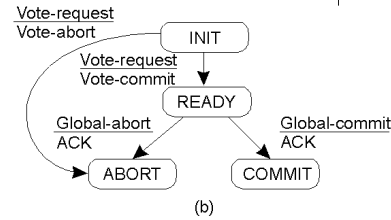
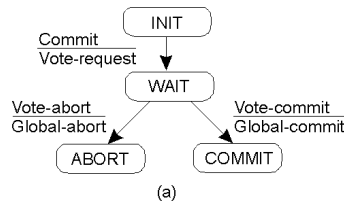
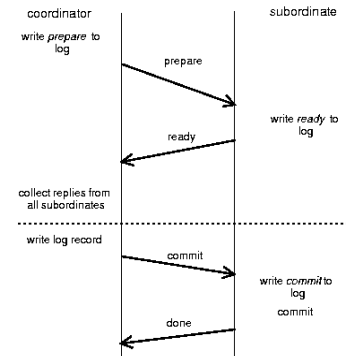

Implementing Two Phase Commit

actions by coordinator:

```

while START_2PC to local log;
multicast VOTE_REQUEST to all participants;
while not all votes have been collected {
  wait for any incoming vote;
  if timeout {
    while GLOBAL_ABORT to local log;
    multicast GLOBAL_ABORT to all participants;
    exit;
  }
  record vote;
}
if all participants sent VOTE_COMMIT and coordinator votes COMMIT{
  write GLOBAL_COMMIT to local log;
  multicast GLOBAL_COMMIT to all participants;
} else {
  write GLOBAL_ABORT to local log;
  multicast GLOBAL_ABORT to all participants;
}

```

- Outline of the steps taken by the coordinator in a two phase commit protocol

Implementing 2PC

actions by participant:

```

write INIT to local log;
wait for VOTE_REQUEST from coordinator;
if timeout {
  write VOTE_ABORT to local log;
  exit;
}
if participant votes COMMIT {
  write VOTE_COMMIT to local log;
  send VOTE_COMMIT to coordinator;
  wait for DECISION from coordinator;
  if timeout {
    multicast DECISION_REQUEST to other participants;
    wait until DECISION is received; /* remain blocked */
    write DECISION to local log;
  }
  if DECISION == GLOBAL_COMMIT
    write GLOBAL_COMMIT to local log;
  else if DECISION == GLOBAL_ABORT
    write GLOBAL_ABORT to local log;
} else {
  write VOTE_ABORT to local log;
  send VOTE_ABORT to coordinator;
}

```

actions for handling decision requests: / *executed by separate thread */

```

while true {
  wait until any incoming DECISION_REQUEST
  is received; /* remain blocked */
  read most recently recorded STATE from the
  local log;
  if STATE == GLOBAL_COMMIT
    send GLOBAL_COMMIT to requesting
    participant;
  else if STATE == INIT or STATE ==
  GLOBAL_ABORT
    send GLOBAL_ABORT to requesting
    participant;
  else
    skip; /* participant remains blocked */
}

```

Recovering from a Crash

- If INIT : abort locally and inform coordinator
- If Ready, contact another process Q and examine Q's state

State of Q	Action by P
COMMIT	Make transition to COMMIT
ABORT	Make transition to ABORT
INIT	Make transition to ABORT
READY	Contact another participant

Three-Phase Commit

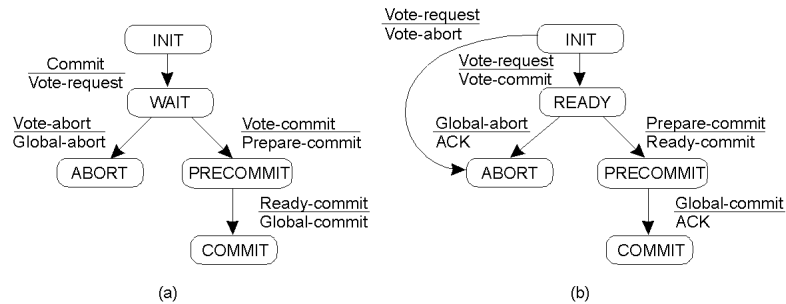

Two phase commit: problem if coordinator crashes (processes block)

Three phase commit: variant of 2PC that avoids blocking

Replication for Fault Tolerance

- Basic idea: use replicas for the server and data
- Technique 1: split incoming requests among replicas
 - If one replica fails, other replicas take over its load
 - Suitable for crash fault tolerance (each replica produces correct results when it is us).
- Technique 2: send each request to all replicas
 - Replicas vote on their results and take majority result
 - Suitable for BFT (a replica can produce wrong results)
 - 2PC, 3PC, Paxos are techniques

Consensus, Agreement

- Consensus vs Byzantine Agreement vs Agreement
- Achieve reliability in presence of faulty processes
 - requires processes to agree on data value needed for computation
 - Examples: whether to commit a transaction, agree on identity of a leader, atomic broadcasts, distributed locks
- Properties of a consensus protocol with fail-stop failures
 - Agreement: every correct process agrees on same value
 - Termination: every correct process decides some value
 - Validity: If all propose v , all correct processes decides v
 - Integrity: Every correct process decided at most one value and if it decides v , someone must have proposed v .

2PC, 3PC Problems

- Both have problems in presence of failures
 - **Safety** is ensured but **liveness** is not
- 2PC
 - must wait for all nodes and coordinator to be up
 - all nodes must vote
 - coordinator must be up
- 3PC
 - handles coordinator failure
 - but network partitions are still an issue
- Paxos : how to reach consensus in distributed systems that can tolerate non-malicious failures?
 - majority rather than all nodes participate

Paxos: fault-tolerant agreement

- Paxos lets nodes agree on same value despite:
 - node failures, network failures and delays
- Use cases:
 - Nodes agree X is primary (or leader)
 - Nodes agree Y is last operation (order operations)
- General approach
 - One (or more) nodes decides to be leader (aka proposer)
 - Leader proposes a value and solicits acceptance from others
 - Leader announces result or tries again
- Proposed independently by Lamport and Liskov
 - Widely used in real systems in major companies

Paxos Requirements

- Safety (Correctness)
 - All nodes agree on the same value
 - Agreed value X was proposed by some node
- Liveness (fault-tolerance)
 - If less than $N/2$ nodes fail, remaining nodes will eventually reach agreement
 - Liveness not guaranteed if steady stream of failures
- Why is agreement hard?
 - Network partitions
 - Leader crashes during solicitation or after deciding but before announcing results,
 - New leader proposes different value from already decided value,
 - More than one node becomes leader simultaneously...

Paxos Setup

- Entities: Proposer (leader), acceptor, learner
 - Leader proposes value, solicits acceptance from acceptors
 - Acceptors are nodes that want to agree; announce chosen value to learners
- Proposals are ordered by proposal #
 - node can choose any high number to try to get proposal accepted
 - An acceptor can accept multiple proposals
 - If prop with value v chosen, all higher proposals have value v
- Each node maintains
 - n_a, v_a : highest proposal # and accepted value
 - n_h : highest proposal # seen so far
 - my_n : my proposal # in current Paxos

Paxos operation: 3 phase protocol

- **Phase 1 (Prepare phase)**
 - A node decides to be a leader and propose
 - Leader chooses $my_n > n_h$
 - Leader sends $\langle prepare, my_n \rangle$ to all nodes
 - Upon receiving $\langle prepare, n \rangle$ at acceptor
 - If $n < n_h$
 - reply $\langle prepare-reject \rangle$ /* already seen higher # proposal */
 - Else
 - $n_h = n$ /* will not accept prop lower than n */
 - reply $\langle prepare-ok, n_a, v_a \rangle$ /* send back previous prop, value/
 - /* can be null, if first */

Paxos operation

- **Phase 2 (accept phase)**
 - If leader gets prepare-ok from **majority**
 - V = non-empty value from highest n_a received
 - If V = null, leader can pick any V
 - Send $\langle \text{accept}, \text{my}_n, V \rangle$ to all nodes
 - If leader fails to get majority prepare-ok
 - delay and restart Paxos
 - Upon receiving $\langle \text{accept}, n, V \rangle$
 - If $n < n_h$
 - reply with $\langle \text{accept-reject} \rangle$
 - else
 - $n_a = n$; $v_a = V$; $n_h = h$; reply $\langle \text{accept-ok} \rangle$

Paxos Operation

- **Phase 3 (decide)**
 - If leader gets accept-ok from majority
 - Send $\langle \text{decide}, v_a \rangle$ to all learners
 - If leader fails to get accept-ok from a majority
 - Delay and restart Paxos
- **Properties**
 - P1: any proposal number is unique
 - P2: any two set of acceptors have at least one node in common
 - P3: value sent in phase 2 is value of highest numbered proposal received in responses in phase 1

Paxos Exampe

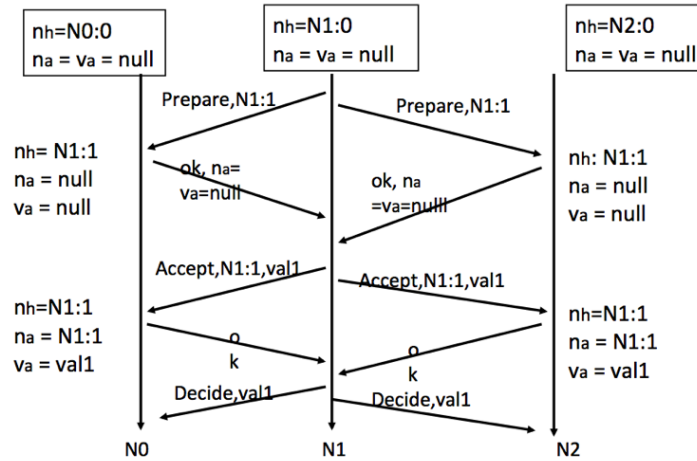

Issues

- Network partitions:
 - With one partition, will have majority on one side and can come to agreement (if nobody fails)
- Timeouts
 - A node has max timeout for each message
 - Upon timeout, declare itself as leader and restart Paxos
- Two leaders
 - Either one leader is not able to decide (does not receive majority accept-oks since nodes see higher proposal from other leader) OR
 - one leader causes the other to use it value
- Leader failures: same as two leaders or timeout occurs

Raft Consensus Protocol

- Paxos is hard to understand (single vs multi-paxos)
- Raft - *understandable* consensus protocol
- **State Machine Replication (SMR)**
 - Implemented as a replicated log
 - Each server stores a log of commands, executes in order
 - Incoming requests → replicate into logs of servers
 - Each server executed request log in order: stays consistent
- Raft: first elect a leader
- Leader sends requests (log entries) to followers
- If **majority** receive entry: safe to apply → commit
 - If entry committed, all entries preceding it are committed

Recovery

- Techniques thus far allow failure handling
- Recovery: operations that must be performed after a failure to recover to a correct state
- Techniques:
 - Checkpointing:
 - Periodically checkpoint state
 - Upon a crash roll back to a previous checkpoint with a *consistent state*

Independent Checkpointing

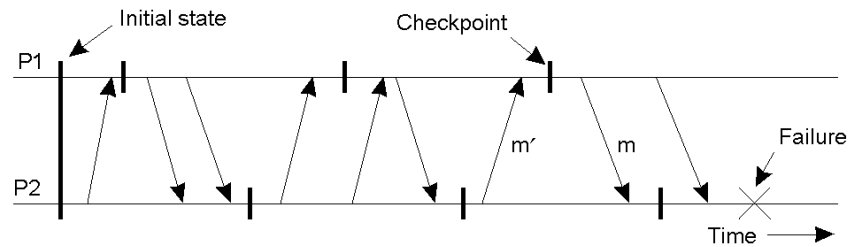

- Each processes periodically checkpoints independently of other processes
- Upon a failure, work backwards to locate a consistent cut
- Problem: if most recent checkpoints form inconsistent cut, will need to keep rolling back until a consistent cut is found
- Cascading rollbacks can lead to a domino effect.

Coordinated Checkpointing

- Take a distributed snapshot [discussed in Lec 11]
- Upon a failure, roll back to the latest snapshot
 - All process restart from the latest snapshot

Logging

- Logging : a common approach to handle failures
 - Log requests / responses received by system on separate storage device / file (stable storage)
 - Used in databases, filesystems, ...
- Failure of a node
 - Some requests may be lost
 - Replay log to “roll forward” system state

Message Logging

- Checkpointing is expensive
 - All processes restart from previous consistent cut
 - Taking a snapshot is expensive
 - Infrequent snapshots => all computations after previous snapshot will need to be redone [wasteful]
- Combine checkpointing (expensive) with message logging (cheap)
 - Take infrequent checkpoints
 - Log all messages between checkpoints to local stable storage
 - To recover: simply replay messages from previous checkpoint
 - Avoids recomputations from previous checkpoint