

Distributed Systems Security

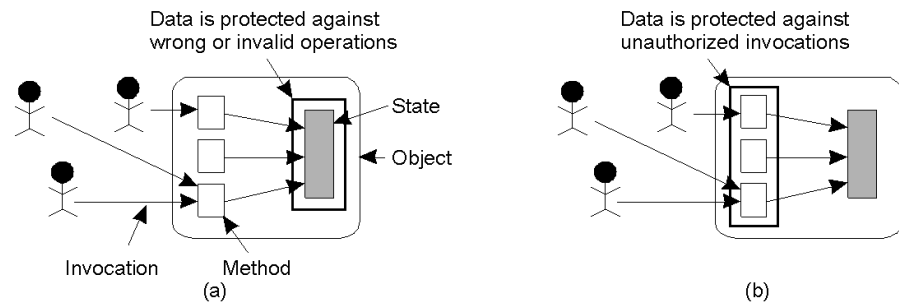

- Three approaches for protection against security threats
 - a) Protection against invalid operations
 - b) Protection against unauthorized invocations
 - c) Protection against unauthorized users

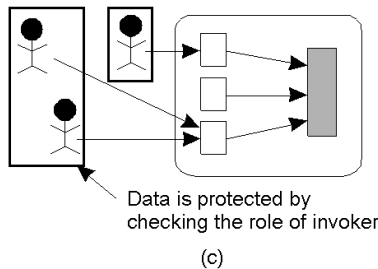

Security and Privacy

- Related but different concepts
- Unauthorized access is a security issue
 - May cause sensitive data (e.g., credit card info, personal info) to be stolen
- Privacy violations can occur without any security violations
 - Mobile app collects location trace for advertising
 - can see visits to a doctor
 - Anonymous browsing history can be de-anonymized
 - Learn internal details of deep neural network from simple request patterns

Authentication

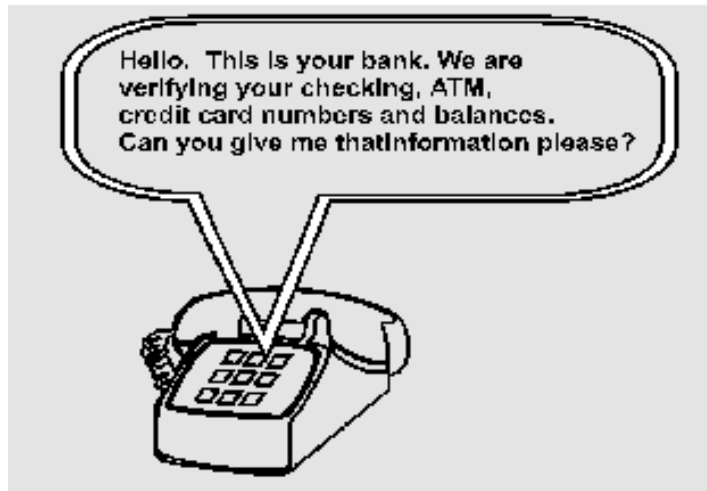

- **Question:** how does a receiver know that remote communicating entity is who it is claimed to be?

Authentication Protocol (ap)

- Ap 1.0
 - Alice to Bob: “I am Alice”
 - Problem: intruder “Trudy” can also send such a message
- Ap 2.0
 - Authenticate source IP address is from Alice’s machine
 - Problem: IP Spoofing (send IP packets with a false address)
- Ap 3.0: use a secret password
 - Alice to Bob: “I am Alice, here is my password” (e.g., telnet)
 - Problem: Trudy can intercept Alice’s password by sniffing packets

Authentication Protocol

Ap 3.1: use encryption

- encryption algorithms provide secrecy: use keys
use a symmetric key known to Alice and Bob

- Alice & Bob (only) know secure key for encryption/decryption

A to B: msg = encrypt("I am A")

B computes: if decrypt(msg)=="I am A"

then A is verified

else A is fraudulent

- failure scenarios: playback attack
 - Trudy can intercept Alice's message and masquerade as Alice at a later time

Authentication Using Nonces

Problem with ap 3.1: same password is used for all sessions

Solution: use a sequence of passwords

pick a "once-in-a-lifetime-only" number (nonce) for each session

Ap 4.0

A to B: msg = "I am A" /* note: unencrypted message! */

B to A: once-in-a-lifetime value, n

A to B: msg2 = encrypt(n) /* use symmetric keys */

B computes: if decrypt(msg2)==n

then A is verified

else A is fraudulent

- note similarities to three way handshake and initial sequence number choice
- problems with nonces?

Authentication Using Public Keys

Ap 4.0 uses symmetric keys for authentication

Question: can we use public keys?

symmetry: $DA(EA(n)) = EA(DA(n))$

AP 5.0

A to B: msg = "I am A"

B to A: once-in-a-lifetime value, n

A to B: msg2 = $DA(n)$

B computes: if $EA(DA(n)) == n$

then A is verified

else A is fraudulent

Problems with Ap 5.0

- Bob needs Alice's public key for authentication
 - Trudy can impersonate as Alice to Bob
 - Trudy to Bob: msg = "I am Alice"
 - Bob to Alice: nonce n (Trudy intercepts this message)
 - Trudy to Bob: msg2 = $DT(n)$
 - Bob to Alice: send me your public key (Trudy intercepts)
 - Trudy to Bob: send ET (claiming it is EA)
 - Bob: verify $ET(DT(n)) == n$ and authenticates Trudy as Alice!!
- Moral: Ap 5.0 is only as "secure" as public key distribution

Man-in-the-middle Attack

- Trudy impersonates as Alice to Bob and as Bob to Alice
 - Alice Trudy Bob
 - “I am A” “I am A”
 - nonce n
 - DT(n)
 - send me ET
 - ET
 - nonce n
 - DA(n)
 - send me EA
 - EA
 - Bob sends data using ET, Trudy decrypts and forwards it using EA!! (Trudy *transparently* intercepts every message)

Digital Signatures Using Public Keys

Goals of digital signatures:

- sender cannot repudiate message never sent ("I never sent that")
- receiver cannot fake a received message

Suppose A wants B to "sign" a message M

B sends $DB(M)$ to A

A computes if $EB (DB(M)) == M$
then B has signed M

Question: can B plausibly deny having sent M?

Message Digests

- Encrypting and decrypting entire messages using digital signatures is computationally expensive
 - Routers routinely exchange data
 - Does not need encryption
 - Needs authentication and verify that data hasn't changed
- Message digests: like a checksum
 - Hash function H : converts variable length string to fixed length hash
 - Digitally sign $H(M)$
 - Send M , $DA(H(m))$
 - Can verify who sent the message and that it has been changed!
- Property of H
 - Given a digest x , it is infeasible to find a message y such that $H(y) = x$
 - It is infeasible to find any two messages x and y such that $H(x) = H(y)$

Hash Functions : MD5

- The structure of MD5

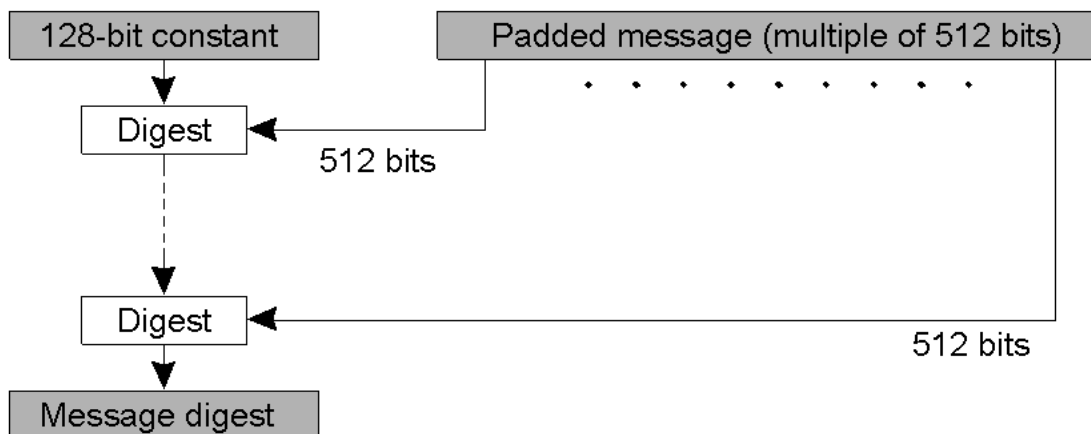

Hash Functions

- MD5 not secure any more
- SHA hash functions (SHA = Secure Hash Algorithm)
 - SHA-1 : 160-bit function that resembles MD5
 - SHA-2: family of two hash functions (SHA-256 and SHA-512)
 - Developed by NIST and NSA

Symmetric key exchange: trusted server

Problem: how do distributed entities agree on a key?

Assume: each entity has its own single key, which only it and trusted server know

Server:

- will generate a one-time session key that A and B use to encrypt communication
- will use A and B's single keys to communicate session key to A, B

Key Exchange: Key Distribution Center (1)

- The principle of using a KDC.

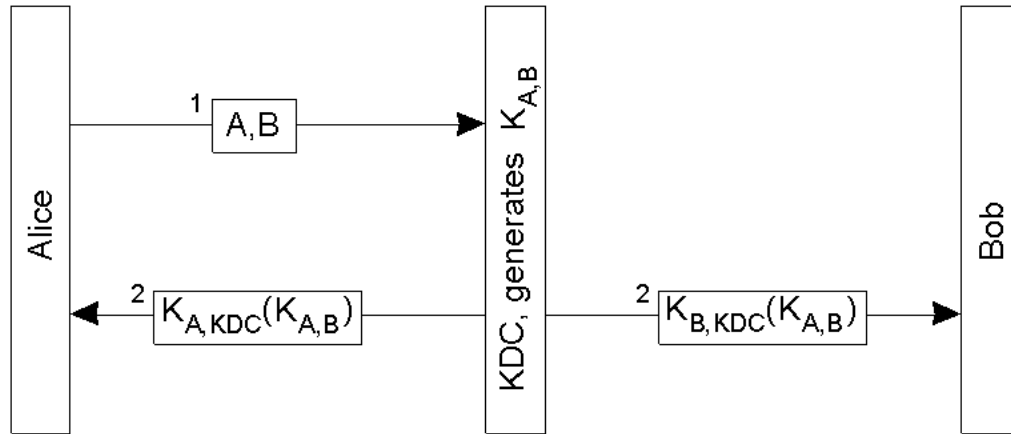

Authentication Using a Key Distribution Center (2)

- Using a ticket and letting Alice set up a connection to Bob.

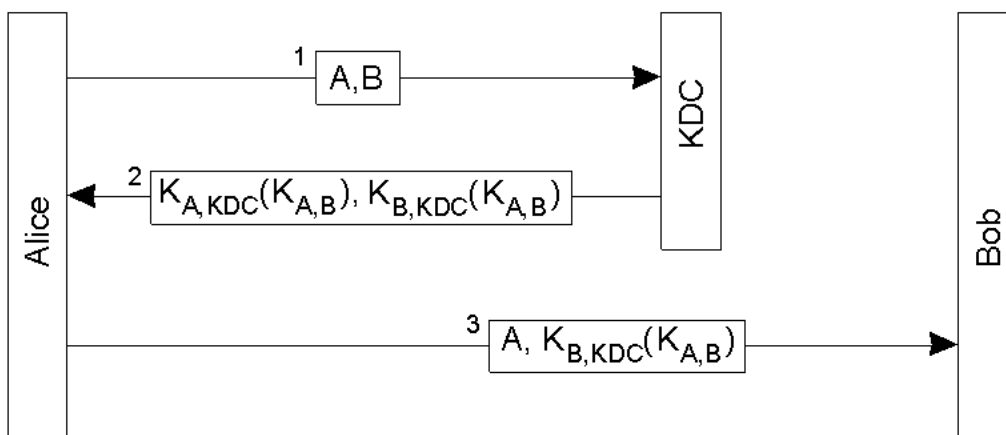

Authentication Using a Key Distribution Center (3)

- The Needham-Schroeder authentication protocol.

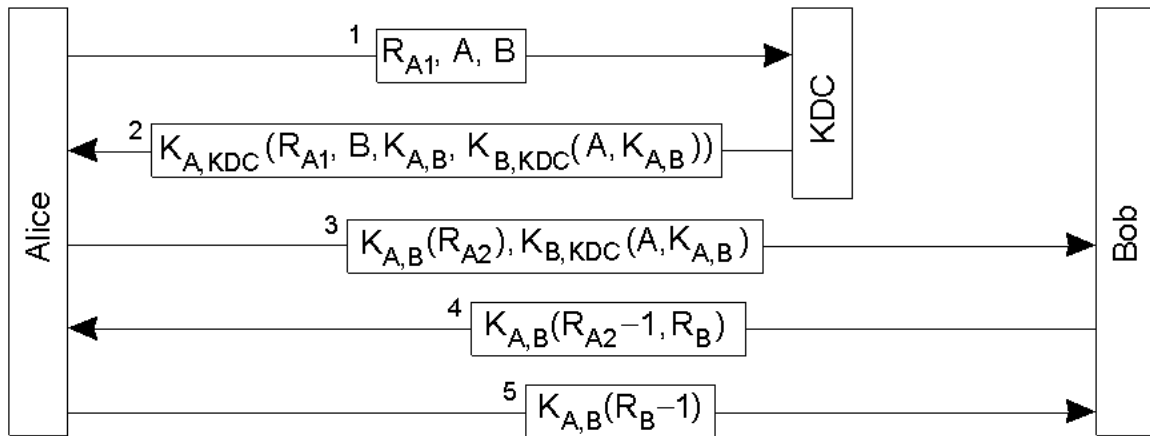

Public Key Exchange

- Mutual authentication in a public-key cryptosystem.

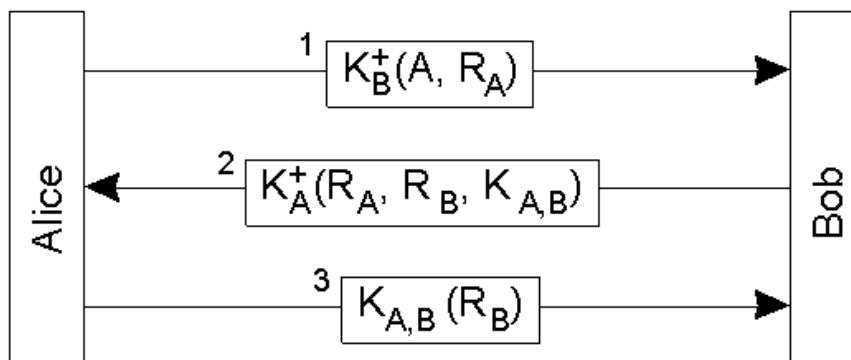

Public key exchange: trusted server

- public key retrieval subject to man-in-middle attack
- locate all public keys in trusted server
- everyone has server's encryption key (ES public)
- suppose A wants to send to B using B's "public" key
- use certificates: public keys signed by certification authority
 - certificates can be revoked as well

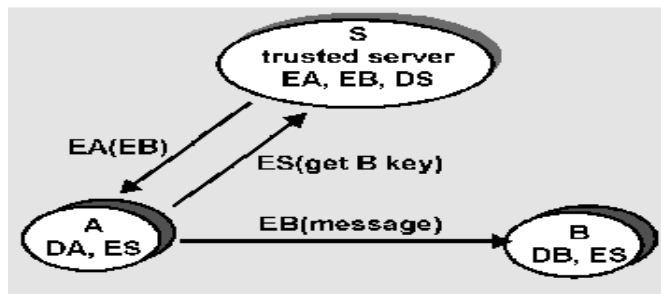

Diffie-Hellman Key Exchange

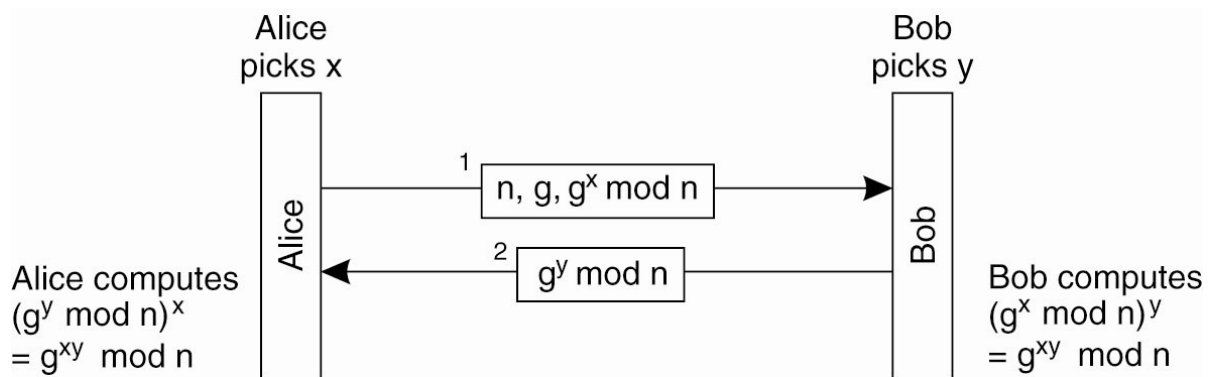

- How to choose a key without encryption
- Agree on n, g – large integers
- Alice choose secret x , Bob chooses secret y

Security in Enterprises

- Multi-layered approach to security in modern enterprises
 - Security functionality spread across multiple entities
- Firewalls (policies + ports)
- Deep Packet inspection
- Virus and email scanners
- VLANs
- Network radius servers
- Securing WiFi
- VPNs
- Securing services using SSL, certificates, kerberos

Security in Internet Services

- Websites
 - SSL + authentication + captchas
- Challenge-response authentication
 - paypal
- Two factor authentication
 - Gmail: password + mobile phone
- One-time passwords
 - Hotmail one-time password
- Online merchant payments: paypal, amazon payments, google checkouts

Protection Against Intruders: Firewalls

- A common implementation of a firewall.

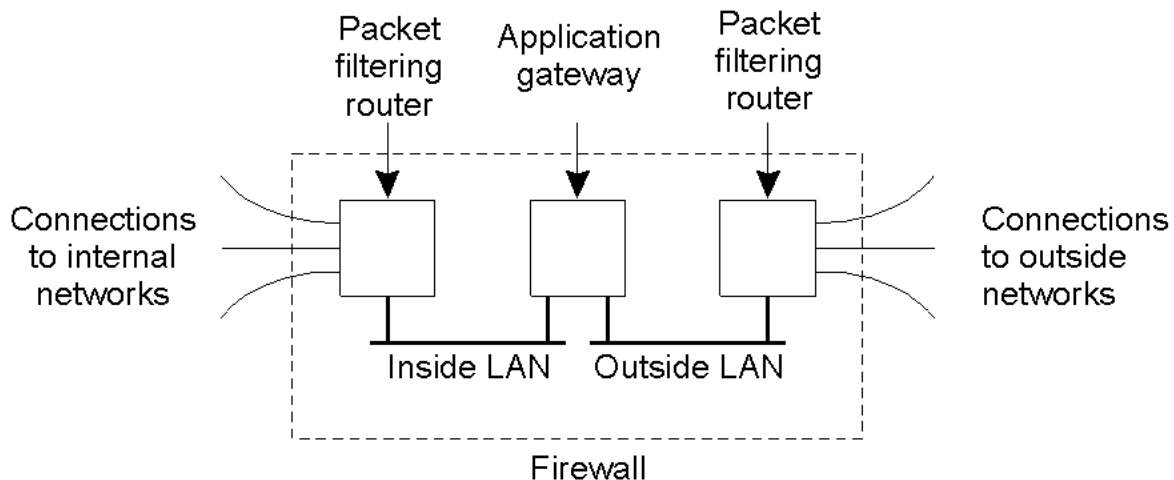

Firewalls

Firewall: network components (host/router+software) sitting between inside ("us") and outside ("them")

Packet filtering firewalls: drop packets on basis of source or destination address (i.e., IP address, port)

Application gateways: application specific code intercepts, processes and/or relays application specific packets

- e.g., email or telnet gateways
- application gateway code can be security hardened
- can log all activity

Access Control

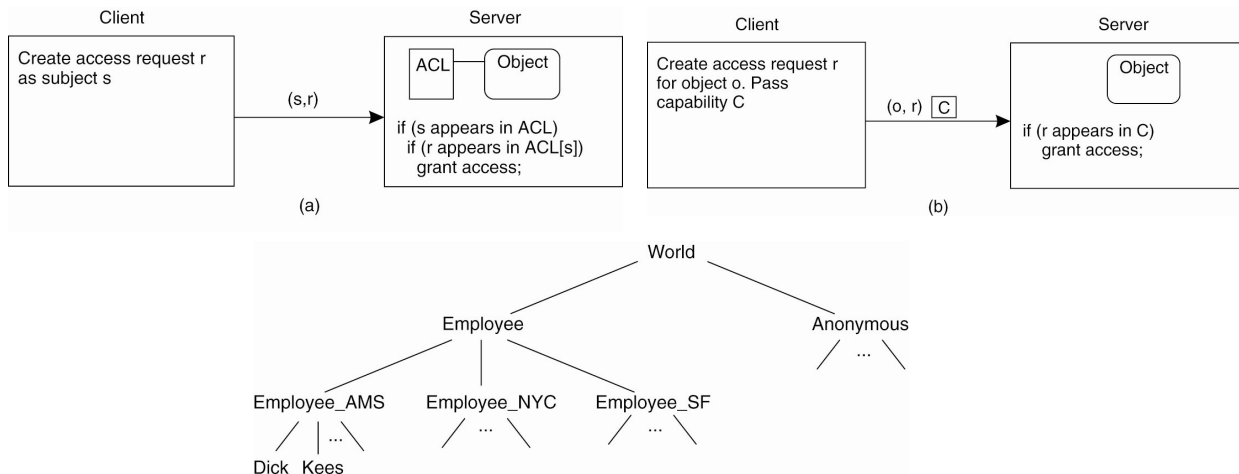

- Access control lists
- Capabilities
- Protection domains

Secure Email

- Requirements:
 - Secrecy
 - Sender authentication
 - Message integrity
 - Receiver authentication
- Secrecy
 - Can use public keys to encrypt messages
 - Inefficient for long messages
 - Use symmetric keys
 - Alice generates a symmetric key K
 - Encrypt message M with K
 - Encrypt K with E_B
 - Send $K(M)$, $E_B(K)$
 - Bob decrypts using his private key, gets K , decrypts $K(M)$

Secure Email

- Authentication and Integrity (with no secrecy)
 - Alice applies hash function H to M (H can be MD5 or SHA)
 - Creates a digital signature $D_A(H(M))$
 - Send $M, D_A(H(M))$ to Bob
- Putting it all together
 - Compute $H(M), D_A(H(M))$
 - $M' = \{ M, D_A(H(M)) \}$
 - Generate symmetric key K , compute $K(M')$
 - Encrypt K as $E_B(K)$
 - Send $K(M'), E_B(K)$
- Used in PGP (pretty good privacy)

Secure Sockets Layer (SSL)

- SSL: Developed by Netscape
 - Provides data encryption and authentication between web server and client
 - SSL lies above the transport layer
 - Useful for Internet Commerce, secure mail access (IMAP)
 - Features:
 - SSL server authentication
 - Encrypted SSL session
 - SSL client authentication

Secure Socket Layer

- Protocol: https instead of http
 - Browser -> Server: B's SSL version and preferences
 - S->B: S's SSL version, preferences, and certificate
 - Certificate: server's RSA public key encrypted by CA's private key
 - B: uses its list of CAs and public keys to decrypt S's public key
 - B->S: generate K, encrypt K with with E_S
 - B->S: "future messages will be encrypted", and $K(m)$
 - S->B: "future messages will be encrypted", and $K(m)$
 - SSL session begins...

Example: Kerberos (1)

- Assist clients in setting up secure channel with a server
- Auth Server (AS) provides login service
- Ticket granting service (TGS) sets up secure channel
 - Tickets are used to convince the server of the authenticity of the client
 - Single signon: no need to auth to other servers separately

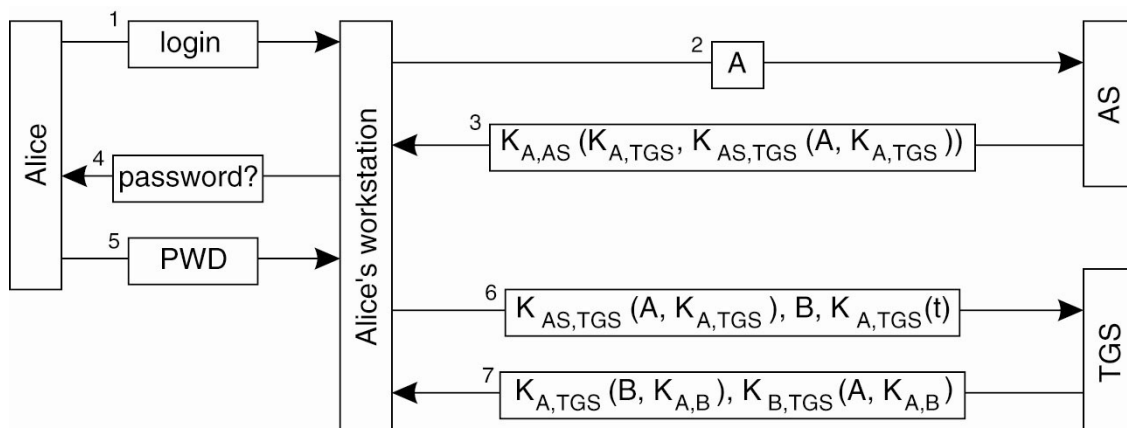

Electronic Payment Systems (1)

- Payment systems based on direct payment between customer and merchant.

- Paying in cash.
- Using a check.
- Using a credit card.

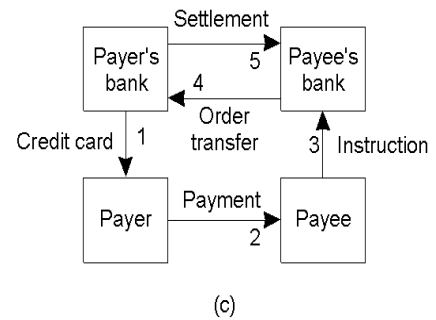
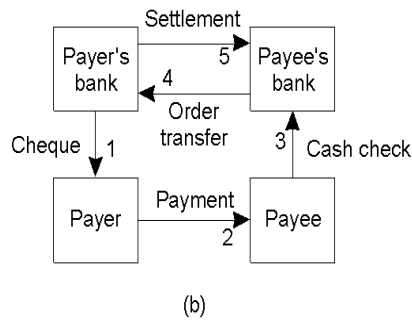
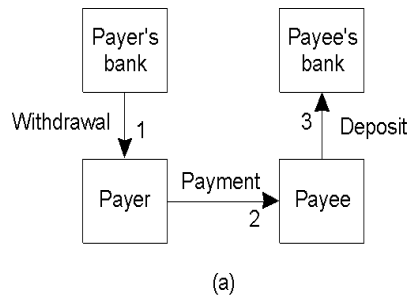

E-cash

- The principle of anonymous electronic cash using blind signatures.

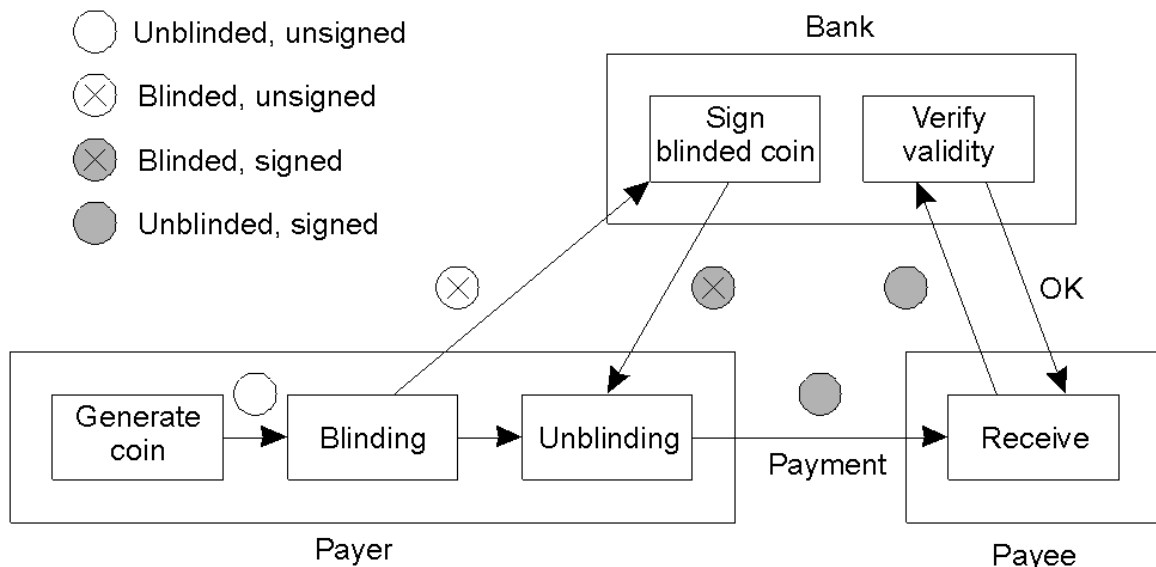

Bitcoin

- Digital currency: P2P electronic cash, Decentralized
 - Open source crypto protocol
 - Satoshi Nakamoto
- New coins made by bitcoin servers
 - expend resources to generate a coin
 - 25 coins generated every 10 minutes
- Uses digital signatures to pay to “public keys”
- Bitcoin blockchain: distributed transaction ledger



Secure Electronic Transactions (SET)

- The different steps in SET

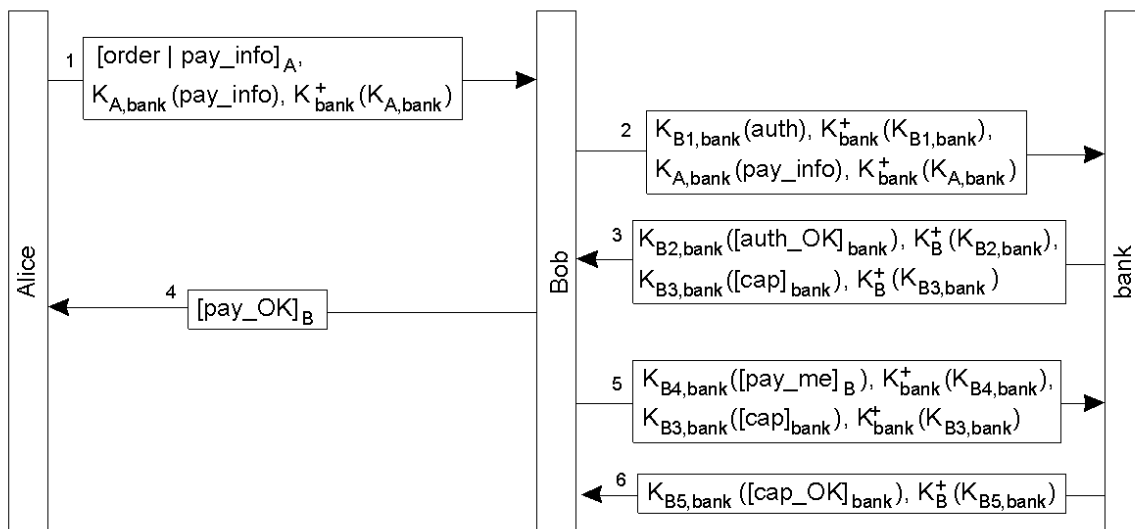

Blockchain: Distributed Ledger

- Blockchain: distributed public ledger of transactions
 - Lists all financial transactions, distributed DB
 - Generic protocol for transactions based on public key cryptography
- **Applications:** stock register, land transactions, marriage records, smart contracts
- **Sign** a transaction with private key and insert in the ledger
- Every block contains multiple transactions
- Massively duplicated; shared using **P2P** file transfer protocol
- Updated by special nodes “miners” to append blocks
- All Network nodes perform validation and clearing
 - Miners perform “settlement” using **distributed consensus**

How Blockchain works

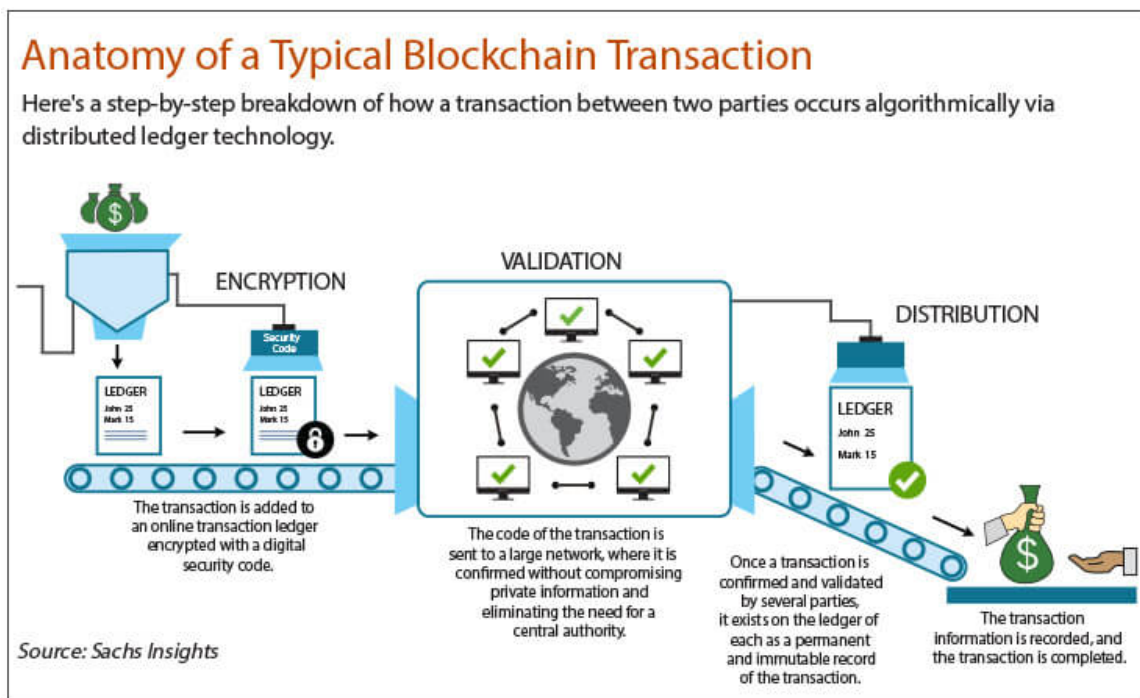

Bitcoin

- Bitcoin: use blockchain to track financial transactions
- Hold bitcoins in a digital wallet, pay for goods & services
- Payment transactions are recorded in the Bitcoin blockchain
-

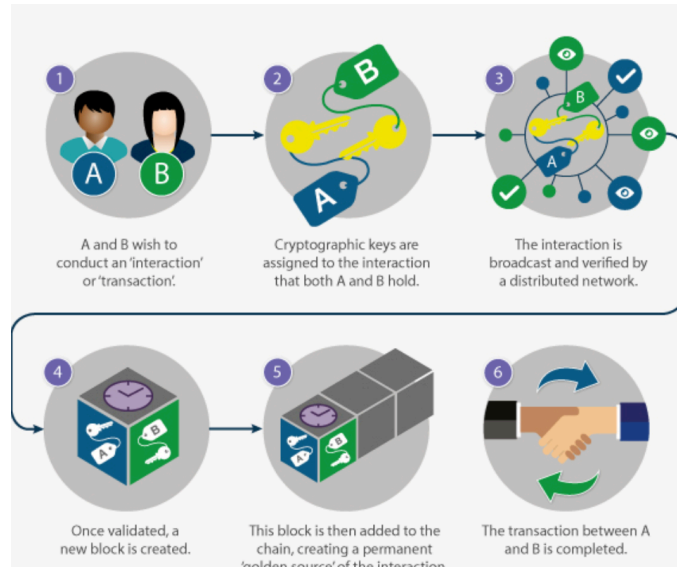

UMassAmherst

CS677: Distributed and Operating Systems

Lecture 26, page 37

Security: conclusion

key concerns:

- encryption
- authentication
- key exchange

also:

- increasingly an important area as network connectivity increases
- digital signatures, digital cash, authentication, increasingly important
- an important social concern
- further reading:
 - Crypto Policy Perspectives: S. Landau et al., Aug 1994 CACM
 - Internet Security, R. Oppliger, CACM May 1997
 - www.eff.org

UMassAmherst

CS677: Distributed and Operating Systems

Lecture 26, page 38