

Consistency and Replication

- Part 1: Replication
- Part 2: Consistency models
 - Data-centric consistency models
 - Client-centric consistency models
- Part 3: Eventual Consistency and Epidemic Protocols

Part 1: Replication Basics

- Data replication versus compute replication
- Data replication: common technique in distributed systems
- Reliability
 - If one replica is unavailable or crashes, use another
 - Protect against corrupted data
- Performance
 - Scale with size of the distributed system (replicated web servers)
 - Scale in geographically distributed systems (web proxies)

Replication Issues

- When to replicate?
- How many replicas to create?
- Where should the replicas located?

- Will return to these issues later (WWW discussion)
- Today: how to maintain *consistency*?
- Key issue: need to maintain *consistency* of replicated data
 - If one copy is modified, others become inconsistent

CAP Theorem

- Conjecture by Eric Brewer at PODC 2000 conference
 - It is impossible for a web service to provide all three guarantees:
 - **Consistency** (nodes see the same data at the same time)
 - **Availability** (node failures do not the rest of the system)
 - **Partition-tolerance** (system can tolerate message loss)
 - A distributed system can satisfy any two, but not all three, at the same time
- Conjecture was established as a theorem in 2002 (by Lynch and Gilbert)

CAP Theorem Examples

- Consistency+Availability
 - Single database, cluster database, LDAP, xFS
 - 2 phase commit
- Consistency + partition tolerance
 - distributed database, distributed locking
 - pessimistic locking
- Availability + Partition tolerance
 - Coda, Web caching, DNS
 - leases, conflict resolution,

NoSQL Systems and CAP

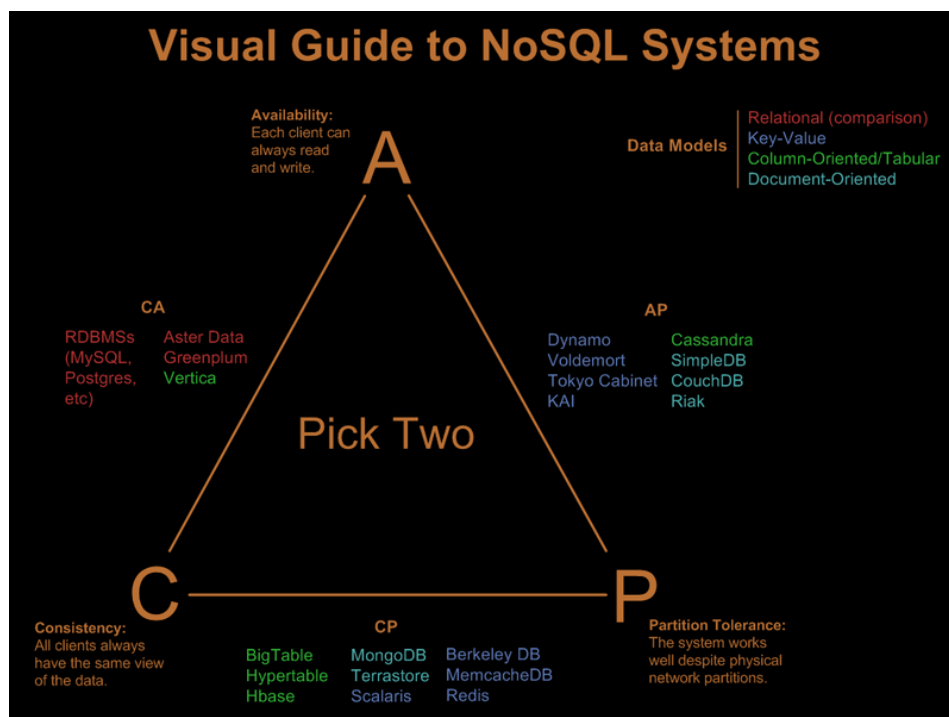
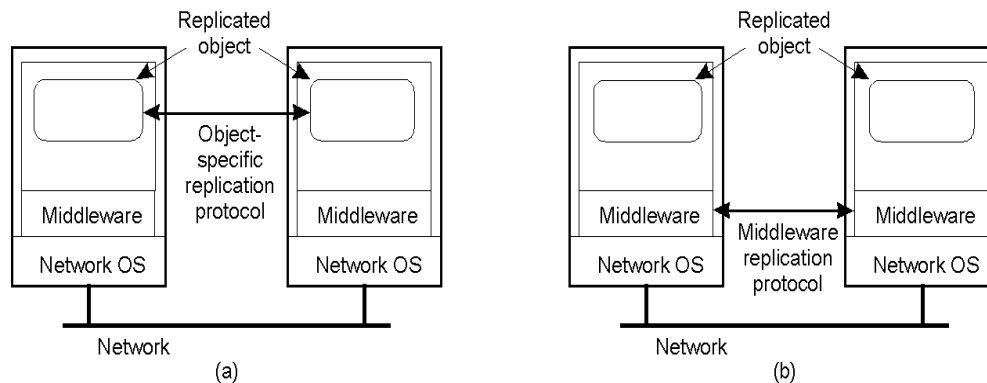

Figure Courtesy of Nathan Hurst

Object Replication



- Approach 1: application is responsible for replication
 - Application needs to handle consistency issues
- Approach 2: system (middleware) handles replication
 - Consistency issues are handled by the middleware
 - Simplifies application development but makes object-specific solutions harder

Replication and Scaling

- Replication and caching used for system scalability
- Multiple copies:
 - Improves performance by reducing access latency
 - But higher network overheads of maintaining consistency
 - Example: object is replicated N times
 - Read frequency R , write frequency W
 - If $R \ll W$, high consistency overhead and wasted messages
 - Consistency maintenance is itself an issue
 - What semantics to provide?
 - Tight consistency requires globally synchronized clocks!
- Solution: loosen consistency requirements
 - Variety of consistency semantics possible

Part 2: Data-Centric Consistency Models

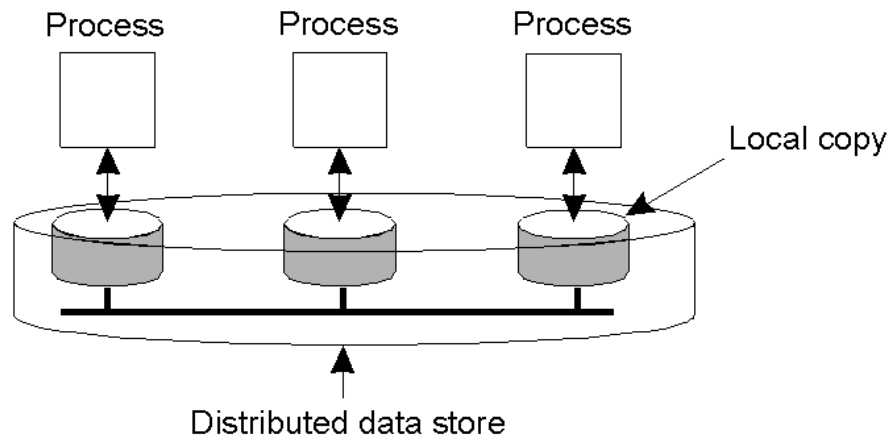

- Consistency model (aka *consistency semantics*)
 - Contract between processes and the data store
 - If processes obey certain rules, data store will work correctly
 - All models attempt to return the results of the last write for a read operation
 - Differ in how “last” write is determined/defined

Strict Consistency

- Any read always returns the result of the most recent write
 - Implicitly assumes the presence of a global clock
 - A write is immediately visible to all processes
 - Difficult to achieve in real systems (network delays can be variable)

Sequential Consistency

- Sequential consistency: weaker than strict consistency
 - Assumes all operations are executed in some sequential order and each process issues operations in program order
 - Any valid interleaving is allowed
 - All agree on the same interleaving
 - Each process preserves its program order
 - Nothing is said about “most recent write”

P1: W(x)a			
P2: W(x)b			
P3: R(x)b R(x)a			
P4: R(x)b R(x)a			

(a)

P1: W(x)a			
P2: W(x)b			
P3: R(x)b R(x)a			
P4: R(x)a R(x)b			

(b)

Linearizability

- Assumes sequential consistency *and*
 - If $TS(x) < TS(y)$ then $OP(x)$ should precede $OP(y)$ in the sequence
 - Stronger than sequential consistency
 - Difference between linearizability and serializability?
 - Granularity: reads/writes versus transactions
- Example:

Process P1	Process P2	Process P3
x = 1; print (y, z);	y = 1; print (x, z);	z = 1; print (x, y);

Linearizability Example

- Four valid execution sequences for the processes of the previous slide. The vertical axis is time.

x = 1;
 print ((y, z);
 y = 1;
 print (x, z);
 z = 1;
 print (x, y);

Prints: 001011

Signature:
 001011
 (a)

x = 1;
 y = 1;
 print (x,z);
 print(y, z);
 z = 1;
 print (x, y);

Prints: 101011

Signature:
 101011
 (b)

y = 1;
 z = 1;
 print (x, y);
 print (x, z);
 x = 1;
 print (y, z);

Prints: 010111

Signature:
 110101
 (c)

y = 1;
 x = 1;
 z = 1;
 print (x, z);
 print (y, z);
 print (x, y);

Prints: 111111

Signature:
 111111
 (d)

Causal consistency

- Causally related writes must be seen by all processes in the same order.
 - Concurrent writes may be seen in different orders on different machines

P1:	W(x)a		
P2:	R(x)a	W(x)b	
P3:		R(x)b	R(x)a
P4:		R(x)a	R(x)b

(a)

Not permitted

P1:	W(x)a		
P2:		W(x)b	
P3:		R(x)b	R(x)a
P4:		R(x)a	R(x)b

(b)

Permitted

Other models

- FIFO consistency: writes from a process are seen by others in the same order. Writes from different processes may be seen in different order (even if causally related)
 - Relaxes causal consistency
 - Simple implementation: tag each write by (Proc ID, seq #)
- Even FIFO consistency may be too strong!
 - Requires all writes from a process be seen in order
- Assume use of critical sections for updates
 - Send final result of critical section everywhere
 - Do not worry about propagating intermediate results
 - Assume presence of synchronization primitives to define semantics

Other Models

Use granularity of critical sections, instead of individual read/write

- Weak consistency
 - Accesses to synchronization variables associated with a data store are sequentially consistent
 - No operation on a synchronization variable is allowed to be performed until all previous writes have been completed everywhere
 - No read or write operation on data items are allowed to be performed until all previous operations to synchronization variables have been performed.
- Entry and release consistency
 - Assume shared data are made consistent at entry or exit points of critical sections

Summary of Data-centric Consistency Models

Consistency	Description
Strict	Absolute time ordering of all shared accesses matters.
Linearizability	All processes must see all shared accesses in the same order. Accesses are furthermore ordered according to a (nonunique) global timestamp
Sequential	All processes see all shared accesses in the same order. Accesses are not ordered in time
Causal	All processes see causally-related shared accesses in the same order.
FIFO	All processes see writes from each other in the order they were used. Writes from different processes may not always be seen in that order

(a)

Consistency	Description
Weak	Shared data can be counted on to be consistent only after a synchronization is done
Release	Shared data are made consistent when a critical region is exited
Entry	Shared data pertaining to a critical region are made consistent when a critical region is entered.

(b)

Client-centric Consistency Models

- Assume read operations by a single process P at two *different* local copies of the same data store
 - Four different consistency semantics
- *Monotonic reads*
 - Once read, subsequent reads on that data items return same or more recent values
- *Monotonic writes*
 - A write must be propagated to all replicas before a successive write by the *same process*
 - Resembles FIFO consistency (writes from same process are processed in same order)
- *Read your writes*: $\text{read}(x)$ always returns $\text{write}(x)$ by that process
- *Writes follow reads*: $\text{write}(x)$ following $\text{read}(x)$ will take place on same or more recent version of x

Part 3: Eventual Consistency

- Many systems: one or few processes perform updates
 - How frequently should these updates be made available to other read-only processes?
- Examples:
 - DNS: single naming authority per domain
 - Only naming authority allowed updates (no write-write conflicts)
 - How should read-write conflicts (consistency) be addressed?
 - NIS: user information database in Unix systems
 - Only sys-admins update database, users only read data
 - Only user updates are changes to password
 - Cloud storage: dropbox, OneDrive, iCloud all use eventual consistency

Eventual Consistency

- Assume a replicated database with few updaters and many readers
- Eventual consistency: in absence of updates, all replicas converge towards identical copies
 - Only requirement: an update should eventually propagate to all replicas
 - Cheap to implement: no or infrequent write-write conflicts
 - Things work fine so long as user accesses same replica
 - What if they don't:

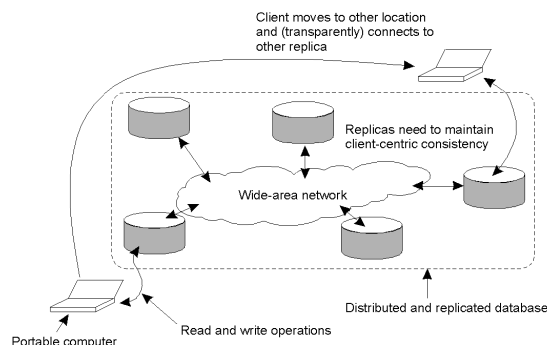

Epidemic Protocols

- Used in Bayou system from Xerox PARC
- Bayou: weakly connected replicas
 - Useful in mobile computing (mobile laptops)
 - Useful in wide area distributed databases (weak connectivity)
- Based on theory of epidemics (*spreading infectious diseases*)
 - Upon an update, try to “infect” other replicas as quickly as possible
 - Pair-wise exchange of updates (*like pair-wise spreading of a disease*)
 - Terminology:
 - Infective store: store with an update it is willing to spread
 - Susceptible store: store that is not yet updated
- Many algorithms possible to spread updates

Spreading an Epidemic

- **Anti-entropy**
 - Server P picks a server Q at random and exchanges updates
 - Three possibilities: only push, only pull, both push and pull
 - Claim: A pure push-based approach does not help spread updates quickly (Why?)
 - Pull or initial push with pull work better
- **Rumor mongering** (aka *gossiping*)
 - Upon receiving an update, P tries to push to Q
 - If Q already received the update, stop spreading with prob $1/k$
 - Analogous to “hot” gossip items => stop spreading if “cold”
 - Does not guarantee that all replicas receive updates
 - Chances of staying susceptible: $s = e^{-(k+1)(1-s)}$

Removing Data

- Deletion of data items is hard in epidemic protocols
- Example: server deletes data item x
 - No state information is preserved
 - Can't distinguish between a deleted copy and no copy!
- Solution: death certificates
 - Treat deletes as updates and spread a death certificate
 - Mark copy as deleted but don't delete
 - Need an eventual clean up
 - Clean up dormant death certificates