

Epidemic Protocols

- Used in Bayou system from Xerox PARC
- Bayou: weakly connected replicas
 - Useful in mobile computing (mobile laptops)
 - Useful in wide area distributed databases (weak connectivity)
- Based on theory of epidemics (*spreading infectious diseases*)
 - Upon an update, try to “infect” other replicas as quickly as possible
 - Pair-wise exchange of updates (*like pair-wise spreading of a disease*)
 - Terminology:
 - Infective store: store with an update it is willing to spread
 - Susceptible store: store that is not yet updated
- Many algorithms possible to spread updates



Spreading an Epidemic

- **Anti-entropy**
 - Server P picks a server Q at random and exchanges updates
 - Three possibilities: only push, only pull, both push and pull
 - Claim: A pure push-based approach does not help spread updates quickly (Why?)
 - Pull or initial push with pull work better
- **Rumor mongering** (aka *gossiping*)
 - Upon receiving an update, P tries to push to Q
 - If Q already received the update, stop spreading with prob $1/k$
 - Analogous to “hot” gossip items => stop spreading if “cold”
 - Does not guarantee that all replicas receive updates
 - Chances of staying susceptible: $s = e^{-(k+1)(1-s)}$



Removing Data

- Deletion of data items is hard in epidemic protocols
- Example: server deletes data item x
 - No state information is preserved
 - Can't distinguish between a deleted copy and no copy!
- Solution: death certificates
 - Treat deletes as updates and spread a death certificate
 - Mark copy as deleted but don't delete
 - Need an eventual clean up
 - Clean up dormant death certificates



Implementation Issues

- Two techniques to implement consistency models
 - Primary-based protocols
 - Assume a primary replica for each data item
 - Primary responsible for coordinating all writes
 - Replicated write protocols
 - No primary is assumed for a data item
 - Writes can take place at any replica



Remote-Write Protocols

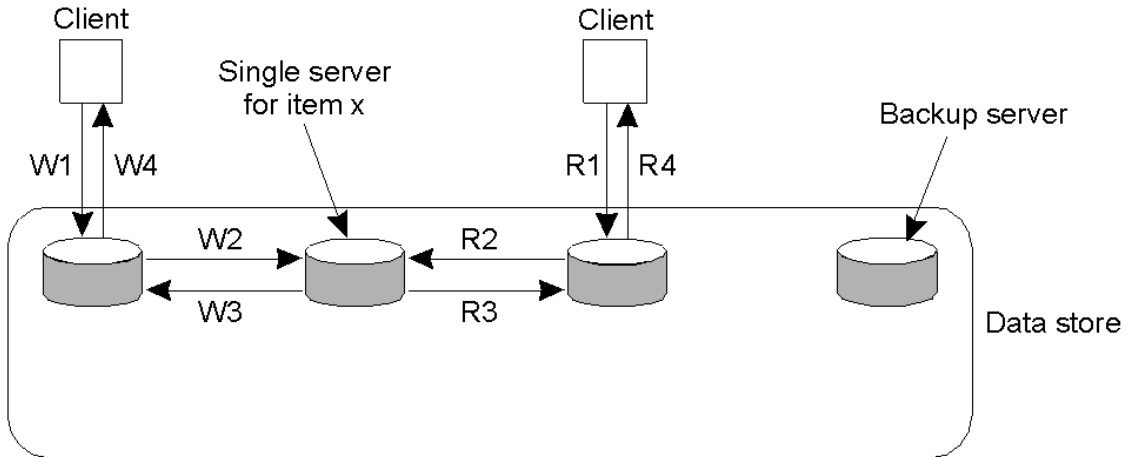

W1. Write request
 W2. Forward request to server for x
 W3. Acknowledge write completed
 W4. Acknowledge write completed

R1. Read request
 R2. Forward request to server for x
 R3. Return response
 R4. Return response

- Traditionally used in client-server systems



Remote-Write Protocols (2)

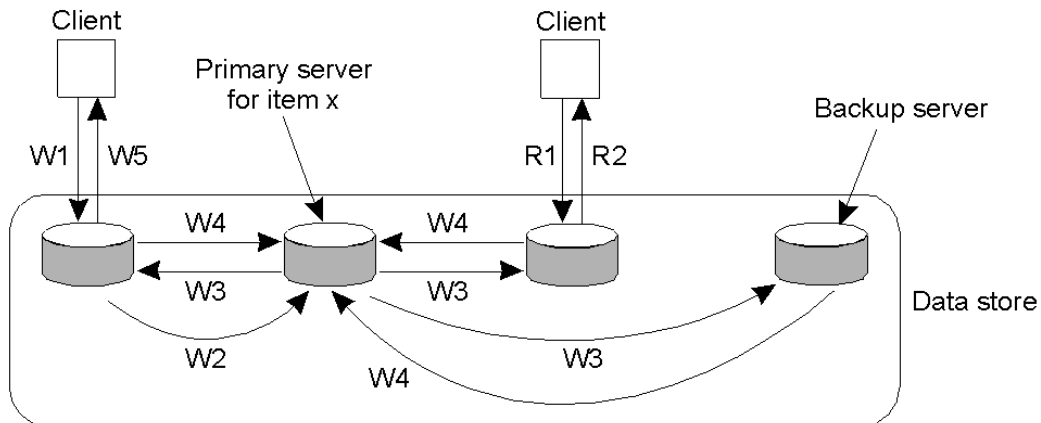

W1. Write request
 W2. Forward request to primary
 W3. Tell backups to update
 W4. Acknowledge update
 W5. Acknowledge write completed

R1. Read request
 R2. Response to read

- Primary-backup protocol
 - Allow local reads, sent writes to primary
 - Block on write until all replicas are notified
 - Implements sequential consistency



Local-Write Protocols (1)

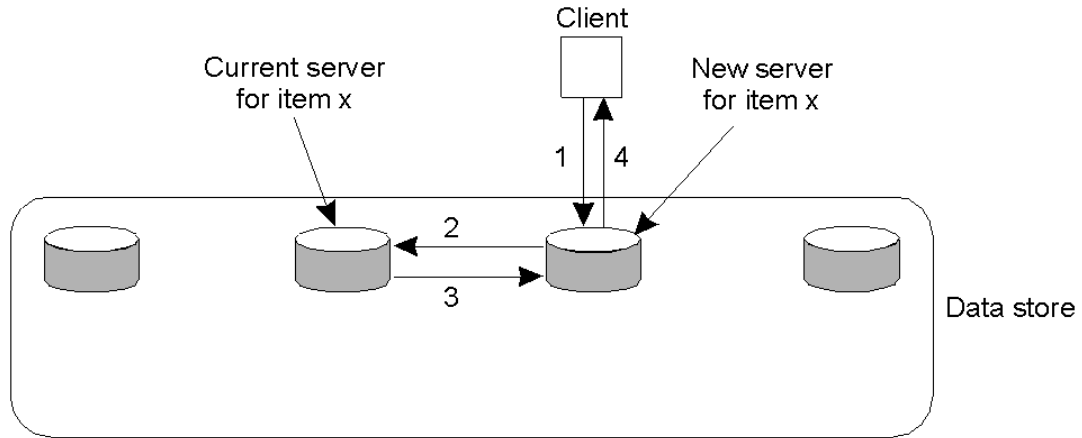

1. Read or write request
2. Forward request to current server for x
3. Move item x to client's server
4. Return result of operation on client's server

- Primary-based local-write protocol in which a single copy is migrated between processes.
 - Limitation: need to track the primary for each data item



Local-Write Protocols (2)

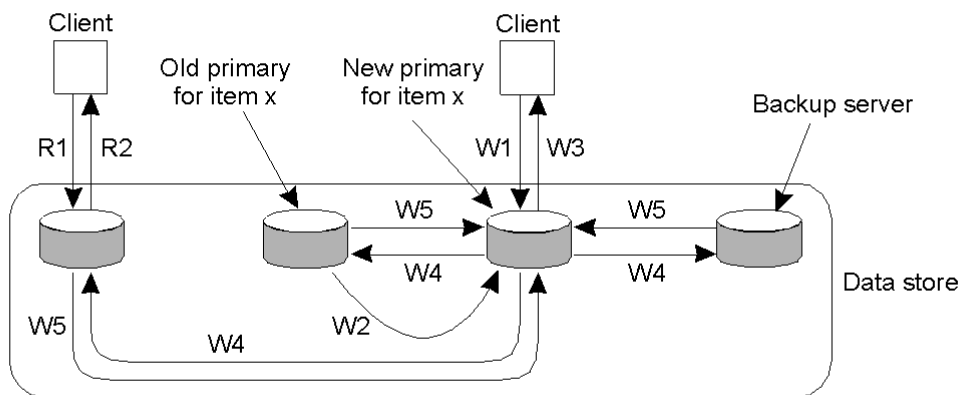

- | | |
|---------------------------------|----------------------|
| W1. Write request | R1. Read request |
| W2. Move item x to new primary | R2. Response to read |
| W3. Acknowledge write completed | |
| W4. Tell backups to update | |
| W5. Acknowledge update | |

- Primary-backup protocol in which the primary migrates to the process wanting to perform an update



Replicated-write Protocols

- Relax the assumption of one primary
 - No primary, any replica is allowed to update
 - Consistency is more complex to achieve
- Quorum-based protocols
 - Use voting to request/acquire permissions from replicas
 - Consider a file replicated on N servers
 - $N_R + N_W > N$ $N_W > N/2$
 - Update: contact at least $(N/2+1)$ servers and get them to agree to do update (associate version number with file)
 - Read: contact majority of servers and obtain version number
 - If majority of servers agree on a version number, read



Gifford's Quorum-Based Protocol

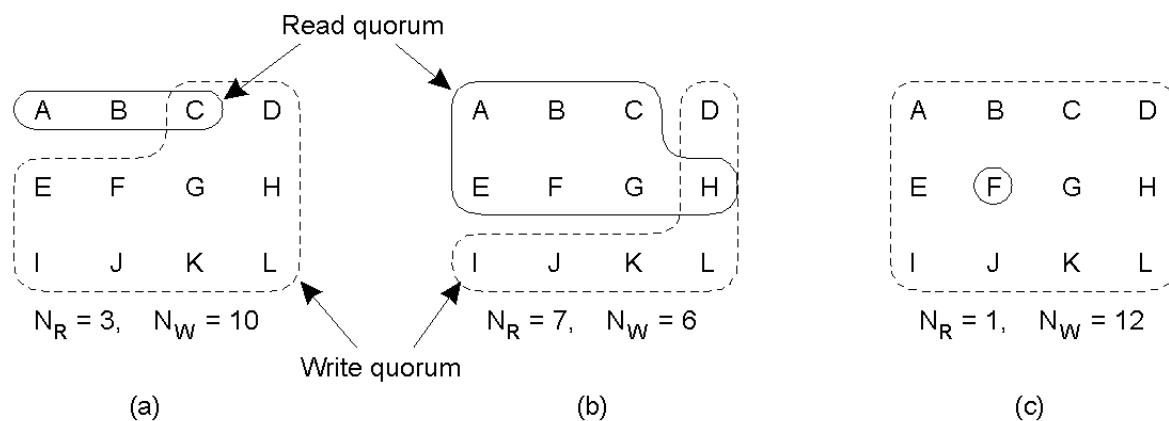

- Three examples of the voting algorithm:
 - a) A correct choice of read and write set
 - b) A choice that may lead to write-write conflicts
 - c) A correct choice, known as ROWA (read one, write all)



Replica Management

- Replica server placement
 - Web: geographically skewed request patterns
 - Where to place a proxy?
 - K-clusters algorithm
- Permanent replicas versus temporary
 - Mirroring: all replicas mirror the same content
 - Proxy server: on demand replication
- Server-initiated versus client-initiated



Content Distribution

- Will come back to this in Chap 12
- CDN: network of proxy servers
- Caching:
 - update versus invalidate
 - Push versus pull-based approaches
 - Stateful versus stateless
- Web caching: what semantics to provide?



Final Thoughts

- Replication and caching improve performance in distributed systems
- Consistency of replicated data is crucial
- Many consistency semantics (models) possible
 - Need to pick appropriate model depending on the application
 - Example: web caching: weak consistency is OK since humans are tolerant to stale information (can reload browser)
 - Implementation overheads and complexity grows if stronger guarantees are desired



Fault Tolerance

- Single machine systems
 - Failures are all or nothing
 - OS crash, disk failures
- Distributed systems: multiple independent nodes
 - Partial failures are also possible (some nodes fail)
- *Question:* Can we automatically recover from partial failures?
 - Important issue since probability of failure grows with number of independent components (nodes) in the systems
 - $\text{Prob}(\text{failure}) = \text{Prob}(\text{Any one component fails}) = 1 - P(\text{no failure})$



A Perspective

- Computing systems are not very reliable
 - OS crashes frequently (Windows), buggy software, unreliable hardware, software/hardware incompatibilities
 - Until recently: computer users were “tech savvy”
 - Could depend on users to reboot, troubleshoot problems
 - Growing popularity of Internet/World Wide Web
 - “Novice” users
 - Need to build more reliable/dependable systems
 - Example: what is your TV (or car) broke down every day?
 - Users don’t want to “restart” TV or fix it (by opening it up)
- Need to make computing systems more reliable
 - Important for online banking, e-commerce, online trading, webmail...



Basic Concepts

- Need to build *dependable* systems
- Requirements for dependable systems
 - Availability: system should be available for use at any given time
 - 99.999 % availability (five 9s) => very small down times
 - Reliability: system should run continuously without failure
 - Safety: temporary failures should not result in a catastrophic
 - Example: computing systems controlling an airplane, nuclear reactor
 - Maintainability: a failed system should be easy to repair



Basic Concepts (contd)

- Fault tolerance: system should provide services despite faults
 - Transient faults
 - Intermittent faults
 - Permanent faults



Failure Models

| Type of failure | Description |
|---|--|
| Crash failure | A server halts, but is working correctly until it halts |
| Omission failure <i>Receive omission</i> <i>Send omission</i> | A server fails to respond to incoming requests A server fails to receive incoming messages A server fails to send messages |
| Timing failure | A server's response lies outside the specified time interval |
| Response failure <i>Value failure</i> <i>State transition failure</i> | The server's response is incorrect The value of the response is wrong The server deviates from the correct flow of control |
| Arbitrary failure | A server may produce arbitrary responses at arbitrary times |

- Different types of failures.



Failure Masking by Redundancy

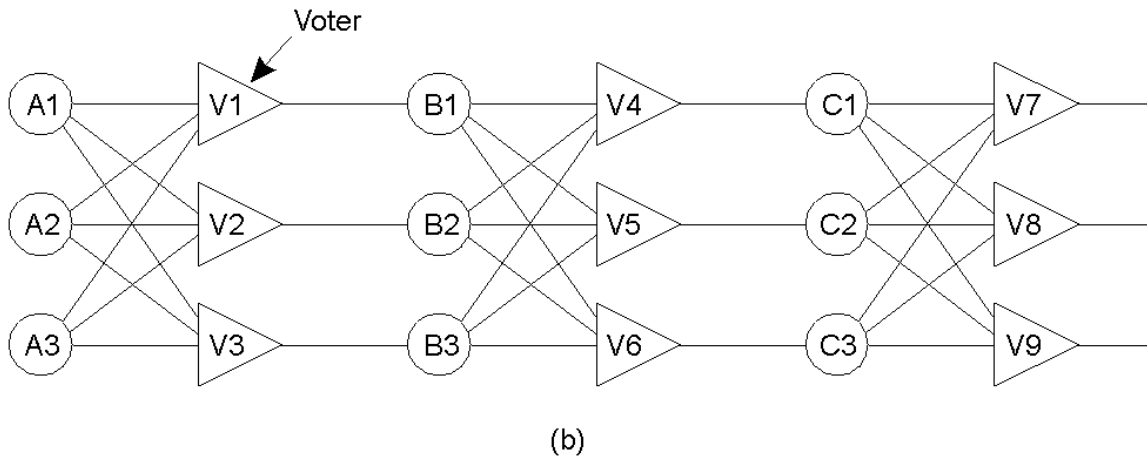
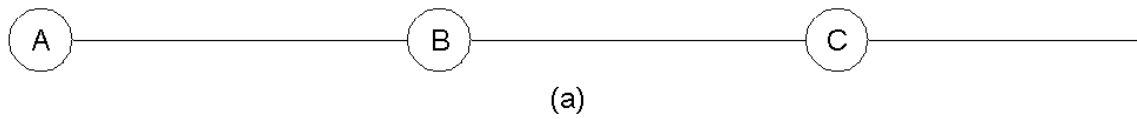

- Triple modular redundancy.

