

Security: Focus of Control

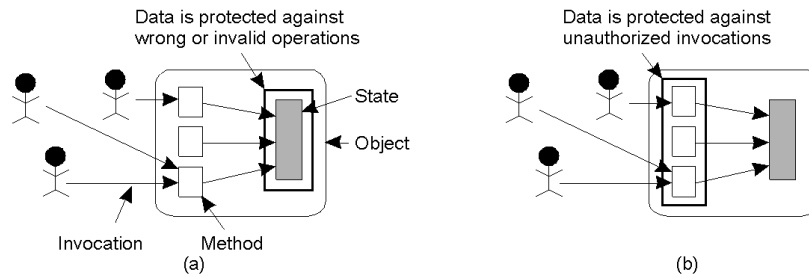

- Three approaches for protection against security threats
 - a) Protection against invalid operations
 - b) Protection against unauthorized invocations
 - c) Protection against unauthorized users

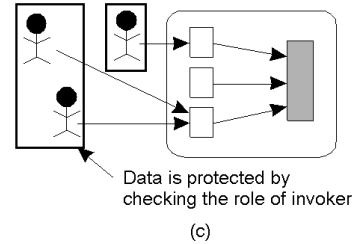

Authentication

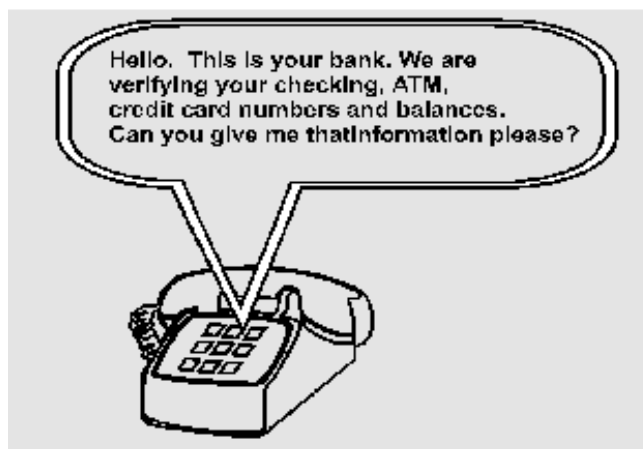

- **Question:** how does a receiver know that remote communicating entity is who it is claimed to be?



Authentication Protocol (ap)

- Ap 1.0
 - Alice to Bob: “I am Alice”
 - Problem: intruder “Trudy” can also send such a message
- Ap 2.0
 - Authenticate source IP address is from Alice’s machine
 - Problem: IP Spoofing (send IP packets with a false address)
- Ap 3.0: use a secret password
 - Alice to Bob: “I am Alice, here is my password” (e.g., telnet)
 - Problem: Trudy can intercept Alice’s password by sniffing packets



Authentication Protocol

Ap 3.1: use encryption

use a symmetric key known to Alice and Bob

- Alice & Bob (only) know secure key for encryption/decryption

A to B: $msg = \text{encrypt}("I \text{ am } A")$

B computes: if $\text{decrypt}(msg) == "I \text{ am } A"$

then A is verified

else A is fraudulent

- failure scenarios: playback attack
 - Trudy can intercept Alice’s message and masquerade as Alice at a later time



Authentication Using Nonces

Problem with ap 3.1: same password is used for all sessions

Solution: use a sequence of passwords

pick a "once-in-a-lifetime-only" number (nonce) for each session

Ap 4.0

A to B: msg = "I am A" /* note: unencrypted message! */

B to A: once-in-a-lifetime value, n

A to B: msg2 = encrypt(n) /* use symmetric keys */

B computes: if decrypt(msg2)==n

then A is verified

else A is fraudulent

- note similarities to three way handshake and initial sequence number choice
- problems with nonces?



Authentication Using Public Keys

Ap 4.0 uses symmetric keys for authentication

Question: can we use public keys?

symmetry: $DA(EA(n)) = EA(DA(n))$

AP 5.0

A to B: msg = "I am A"

B to A: once-in-a-lifetime value, n

A to B: msg2 = DA(n)

B computes: if EA(DA(n)) == n

then A is verified

else A is fraudulent



Digital Signatures Using Public Keys

Goals of digital signatures:

- sender cannot repudiate message never sent ("I never sent that")
- receiver cannot fake a received message

Suppose A wants B to "sign" a message M

B sends $DB(M)$ to A

A computes if $EB (DB(M)) == M$

then B has signed M



Question: can B plausibly deny having sent M?

Computer Science

CS677: Distributed OS

Lecture 19, page 9

Message Digests

- Encrypting and decrypting entire messages using digital signatures is computationally expensive
 - Routers routinely exchange data
 - Does not need encryption
 - Needs authentication and verify that data hasn't changed
- Message digests: like a checksum
 - Hash function H: converts variable length string to fixed length hash
 - Digitally sign $H(M)$
 - Send M, $DA(H(m))$
 - Can verify who sent the message and that it has been changed!
- Property of H
 - Given a digest x, it is infeasible to find a message y such that $H(y) = x$
 - It is infeasible to find any two messages x and y such that $H(x) = H(y)$



Computer Science

CS677: Distributed OS

Lecture 19, page 10

Hash Functions : MD5

- The structure of MD5

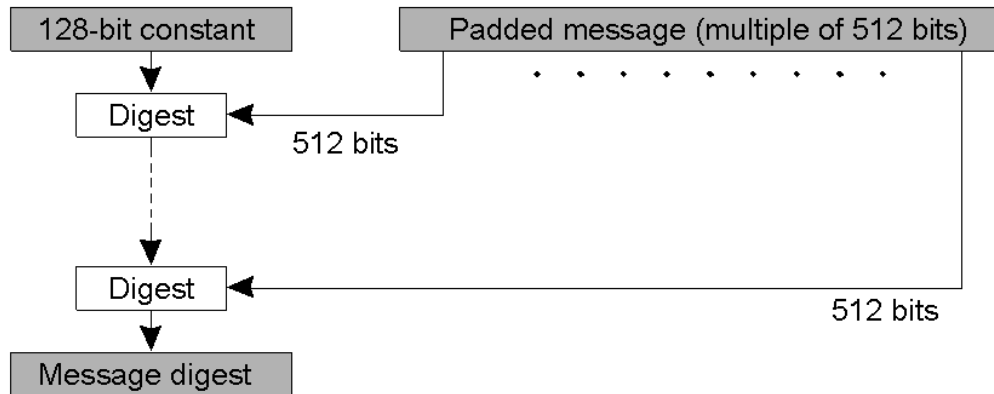

Symmetric key exchange: trusted server

Problem: how do distributed entities agree on a key?

Assume: each entity has its own single key, which only it and trusted server know

Server:

- will generate a one-time session key that A and B use to encrypt communication
- will use A and B's single keys to communicate session key to A, B



Key Exchange: Key Distribution Center (1)

- The principle of using a KDC.

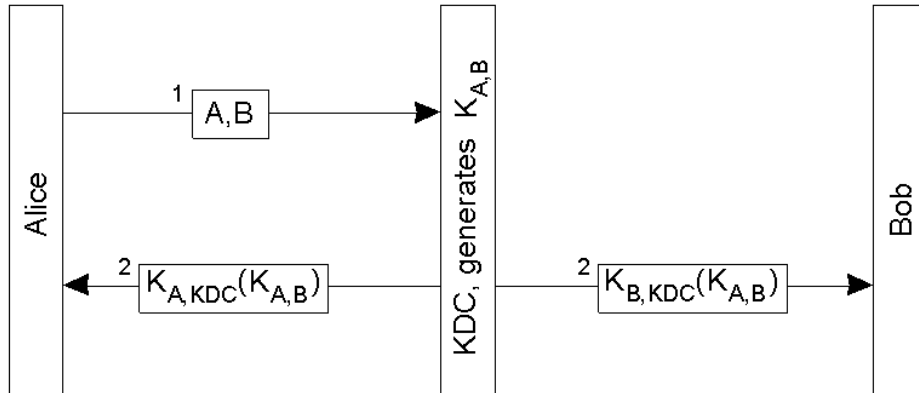

Authentication Using a Key Distribution Center (2)

- Using a ticket and letting Alice set up a connection to Bob.

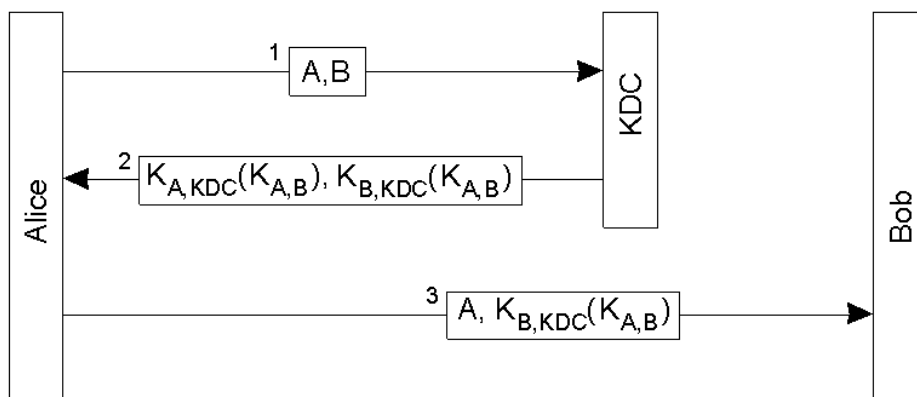

Authentication Using a Key Distribution Center (3)

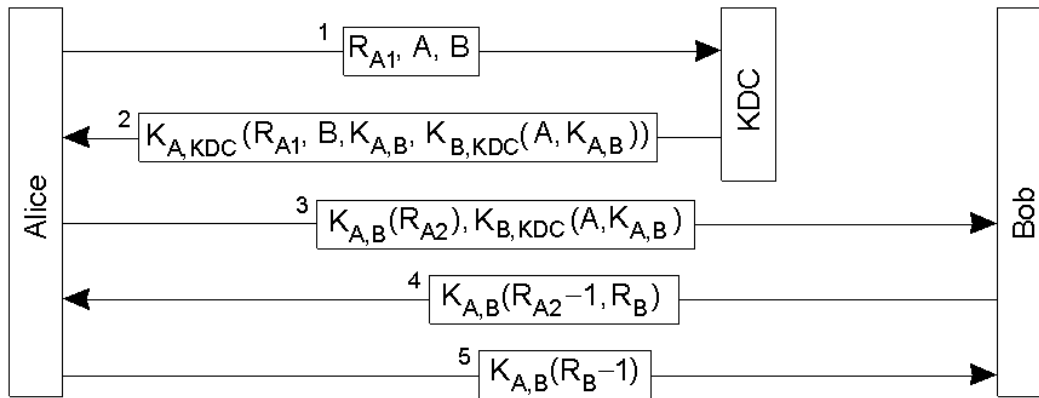

Public Key Exchange

- Mutual authentication in a public-key cryptosystem.

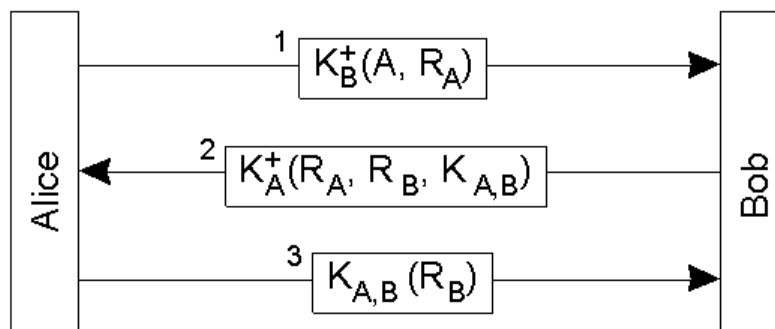

Public key exchange: trusted server

- public key retrieval subject to man-in-middle attack
- locate all public keys in trusted server
- everyone has server's encryption key (ES public)
- suppose A wants to send to B using B's "public" key

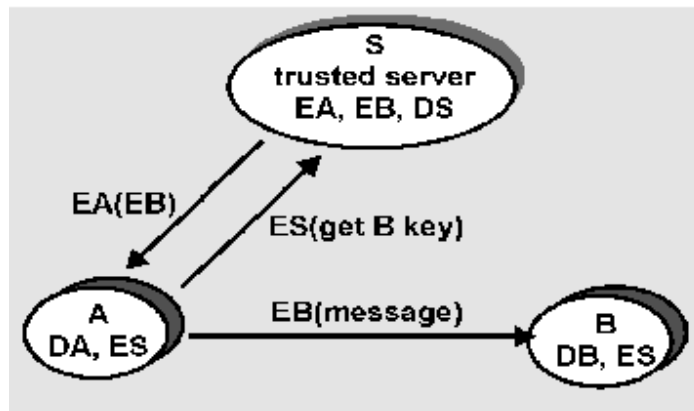

Diffie-Hellman Key Exchange

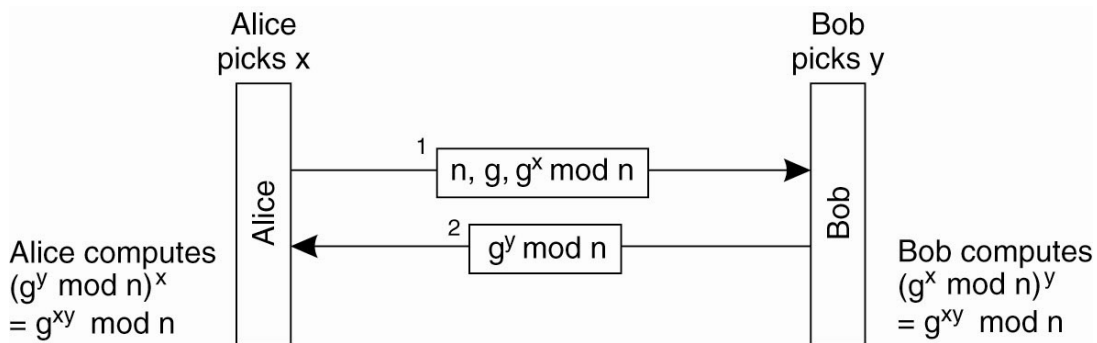

- How to choose a key without encryption
- Agree on n, g – large integers
- Alice choose secret x, Bob chooses secret y



Access Control

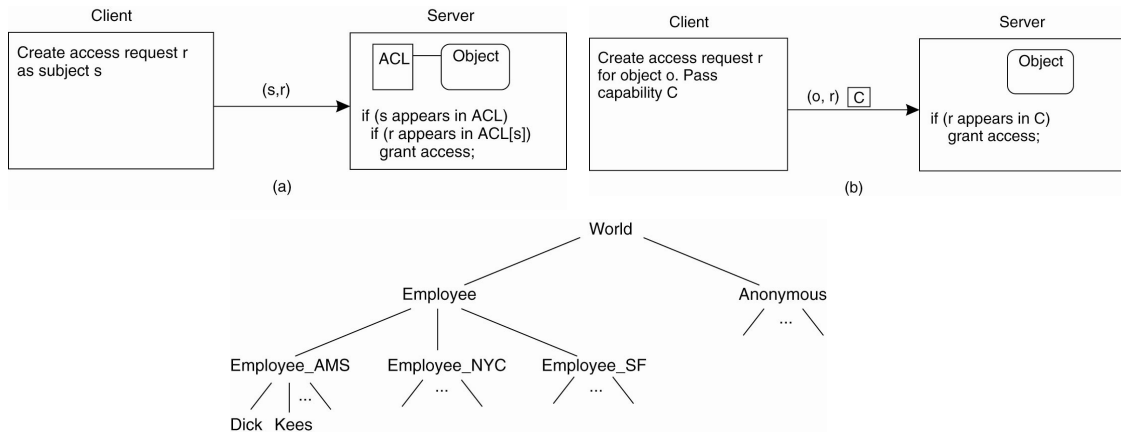

- Access control lists
- Capabilities
- Protection domains



Protection Against Intruders: Firewalls

- A common implementation of a firewall.

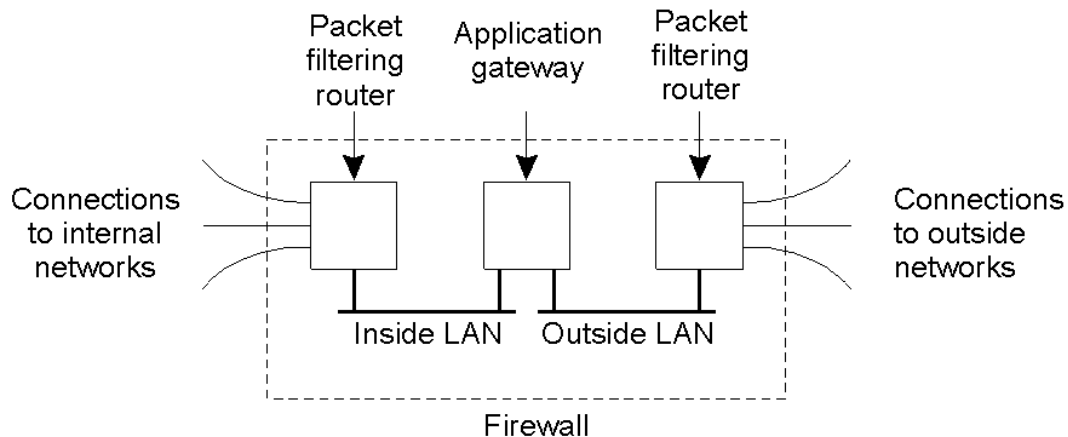

Firewalls

Firewall: network components (host/router+software) sitting between inside ("us") and outside ("them")

Packet filtering firewalls: drop packets on basis of source or destination address (i.e., IP address, port)

Application gateways: application specific code intercepts, processes and/or relays application specific packets

- e.g., email of telnet gateways
- application gateway code can be security hardened
- can log all activity



Secure Email

- Requirements:
 - Secrecy
 - Sender authentication
 - Message integrity
 - Receiver authentication
- Secrecy
 - Can use public keys to encrypt messages
 - Inefficient for long messages
 - Use symmetric keys
 - Alice generates a symmetric key K
 - Encrypt message M with K
 - Encrypt K with E_B
 - Send $K(M), E_B(K)$
 - Bob decrypts using his private key, gets K , decrypts $K(M)$



Secure Email

- Authentication and Integrity (with no secrecy)
 - Alice applies hash function H to M (H can be MD5)
 - Creates a digital signature $D_A(H(M))$
 - Send $M, D_A(H(M))$ to Bob
- Putting it all together
 - Compute $H(M), D_A(H(M))$
 - $M' = \{ H(M), D_A(H(M)) \}$
 - Generate symmetric key K , compute $K(M')$
 - Encrypt K as $E_B(K)$
 - Send $K(M'), E_B(K)$
- Used in PGP (pretty good privacy)



Secure Sockets Layer (SSL)

- SSL: Developed by Netscape
 - Provides data encryption and authentication between web server and client
 - SSL lies above the transport layer
 - Useful for Internet Commerce, secure mail access (IMAP)
 - Features:
 - SSL server authentication
 - Encrypted SSL session
 - SSL client authentication



Secure Socket Layer

- Protocol: https instead of http
 - Browser -> Server: B's SSL version and preferences
 - S->B: S's SSL version, preferences, and certificate
 - Certificate: server's RSA public key encrypted by CA's private key
 - B: uses its list of CAs and public keys to decrypt S's public key
 - B->S: generate K, encrypt K with with E_S
 - B->S: "future messages will be encrypted", and $K(m)$
 - S->B: "future messages will be encrypted", and $K(m)$
 - SSL session begins...



Example: Kerberos (1)

- Assist clients in setting up secure channel with a server
- Auth Server (AS) provides login service
- Ticket granting service (TGS) sets up secure channel
 - Tickets are used to convince the server of the authenticity of the client
 - Single signon: no need to auth to other servers separately

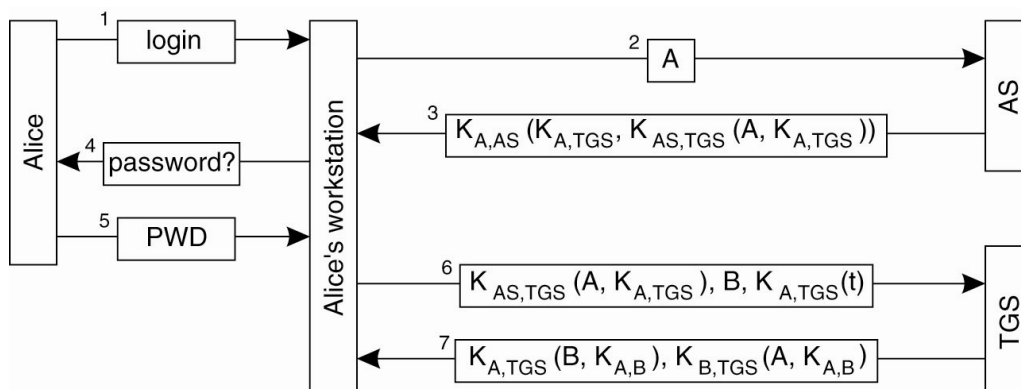

Electronic Payment Systems (1)

- Payment systems based on direct payment between customer and merchant.
- a) Paying in cash.
- b) Using a check.
- c) Using a credit card.

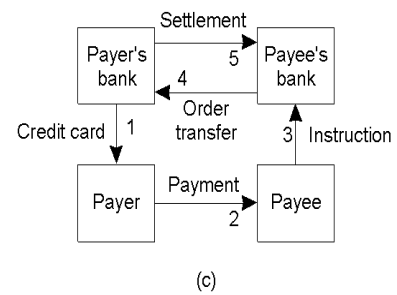
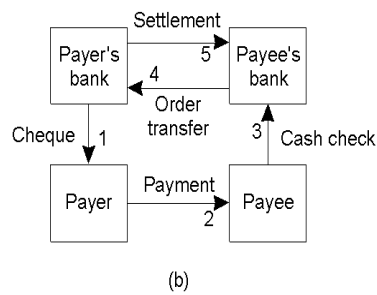
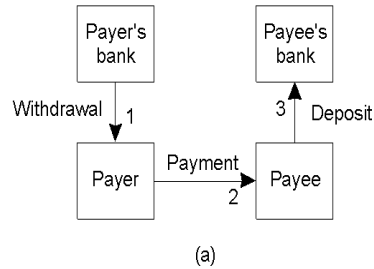

E-cash

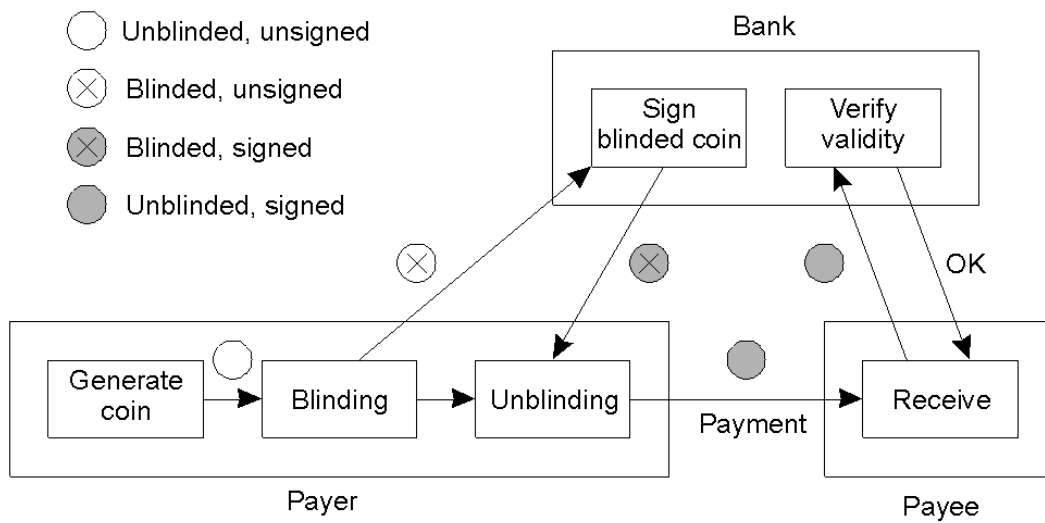

Secure Electronic Transactions (SET)

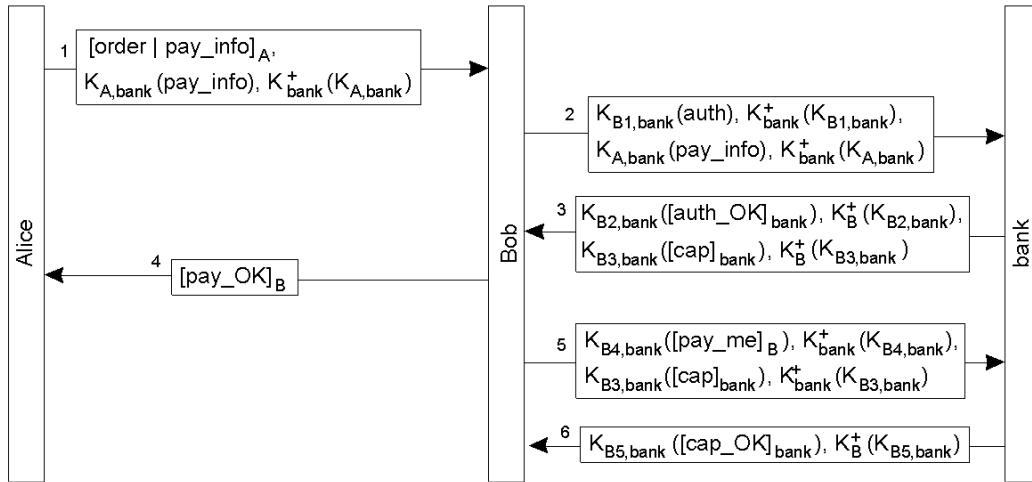

Security: conclusion

key concerns:

- encryption
- authentication
- key exchange

also:

- increasingly an important area as network connectivity increases
- digital signatures, digital cash, authentication, increasingly important
- an important social concern
- further reading:
 - Crypto Policy Perspectives: S. Landau et al., Aug 1994 CACM
 - Internet Security, R. Oppliger, CACM May 1997
 - www.eff.org

