

Last Class: RPCs and RMI

- Case Study: Sun RPC
- Lightweight RPCs
- Remote Method Invocation (RMI)
 - Design issues



Today: Communication Issues

- Message-oriented communication
 - Persistence and synchronicity
- Stream-oriented communication



Persistence and Synchronicity in Communication

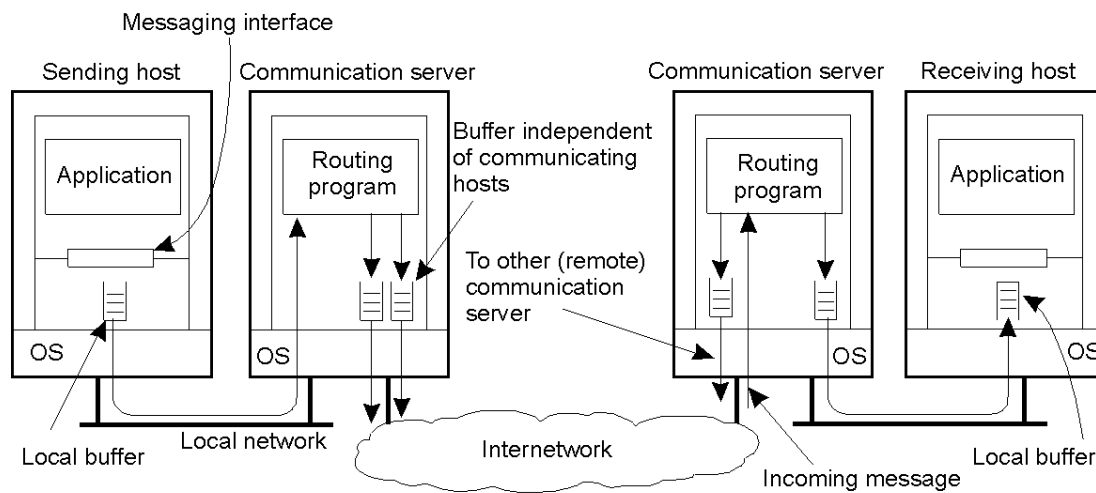

Persistence

- Persistent communication
 - Messages are stored until (next) receiver is ready
 - Examples: email, pony express

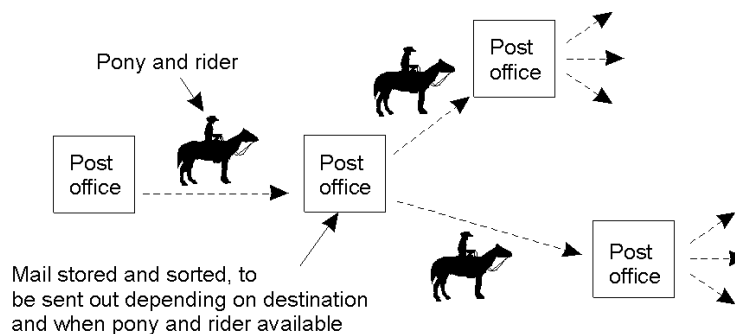

Transient Communication

- Transient communication
 - Message is stored only so long as sending/receiving application are executing
 - Discard message if it can't be delivered to next server/receiver
 - Example: transport-level communication services offer transient communication
 - Example: Typical network router – discard message if it can't be delivered next router or destination



Synchronicity

- Asynchronous communication
 - Sender continues immediately after it has submitted the message
 - Need a local buffer at the sending host
- Synchronous communication
 - Sender blocks until message is stored in a local buffer at the receiving host or actually delivered to sending
 - Variant: block until receiver processes the message
- Six combinations of persistence and synchronicity



Persistence and Synchronicity Combinations

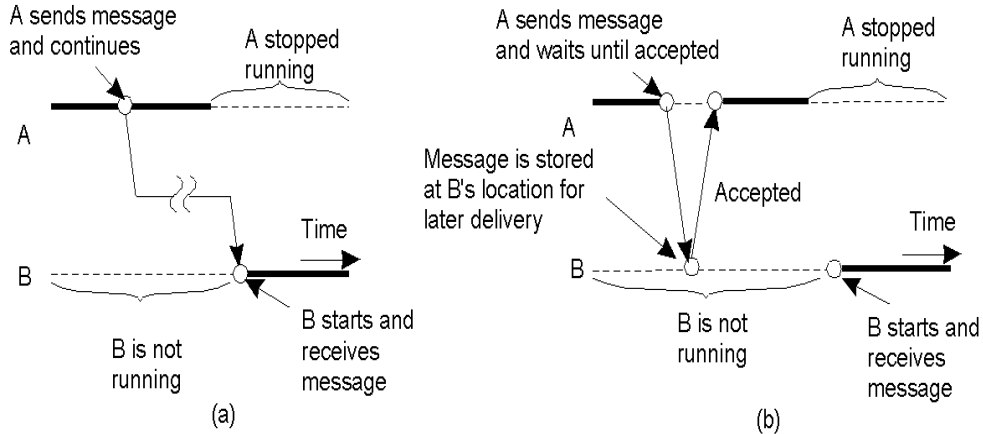

- a) Persistent asynchronous communication (e.g., email)
- b) Persistent synchronous communication



Persistence and Synchronicity Combinations

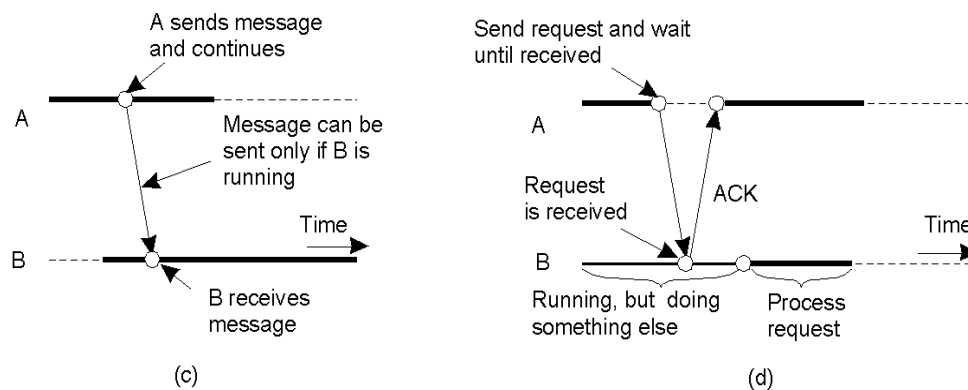

- c) Transient asynchronous communication (e.g., UDP)
- d) Receipt-based transient synchronous communication



Persistence and Synchronicity Combinations

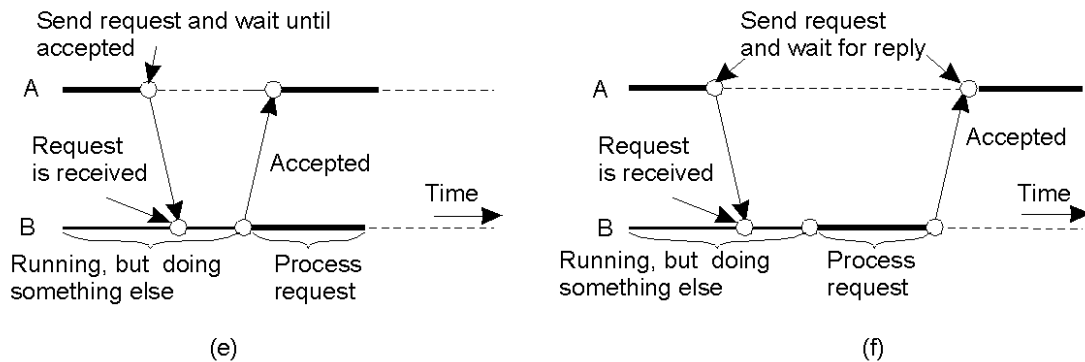

- e) Delivery-based transient synchronous communication at message delivery (e.g., asynchronous RPC)
- f) Response-based transient synchronous communication (RPC)



Message-oriented Transient Communication

- Many distributed systems built on top of simple message-oriented model
 - Example: Berkeley sockets

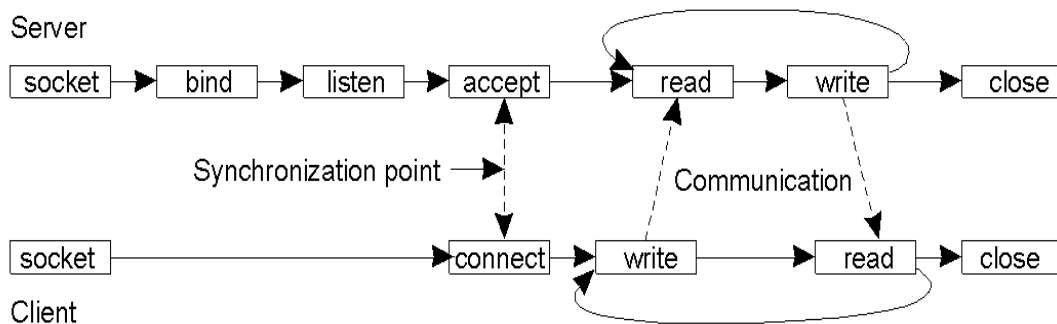

Berkeley Socket Primitives

Primitive	Meaning
Socket	Create a new communication endpoint
Bind	Attach a local address to a socket
Listen	Announce willingness to accept connections
Accept	Block caller until a connection request arrives
Connect	Actively attempt to establish a connection
Send	Send some data over the connection
Receive	Receive some data over the connection
Close	Release the connection



Message-Passing Interface (MPI)

- Sockets designed for network communication (e.g., TCP/IP)
 - Support simple send/receive primitives
- Abstraction not suitable for other protocols in clusters of workstations or massively parallel systems
 - Need an interface with more advanced primitives
- Large number of incompatible proprietary libraries and protocols
 - Need for a standard interface
- Message-passing interface (MPI)
 - Hardware independent
 - Designed for parallel applications (uses *transient communication*)
- Key idea: communication between groups of processes
 - Each endpoint is a (*groupID*, *processID*) pair



MPI Primitives

Primitive	Meaning
MPI_bsend	Append outgoing message to a local send buffer
MPI_send	Send a message and wait until copied to local or remote buffer
MPI_ssend	Send a message and wait until receipt starts
MPI_sendrecv	Send a message and wait for reply
MPI_issend	Pass reference to outgoing message, and continue
MPI_issend	Pass reference to outgoing message, and wait until receipt starts
MPI_recv	Receive a message; block if there are none
MPI_irecv	Check if there is an incoming message, but do not block



Message-oriented Persistent Communication

- Message queuing systems
 - Support asynchronous persistent communication
 - Intermediate storage for message while sender/receiver are inactive
 - Example application: email
- Communicate by inserting messages in queues
- Sender is only guaranteed that message will be eventually inserted in recipient's queue
 - No guarantees on when or if the message will be read
 - “Loosely coupled communication”



Message-Queuing Model (1)

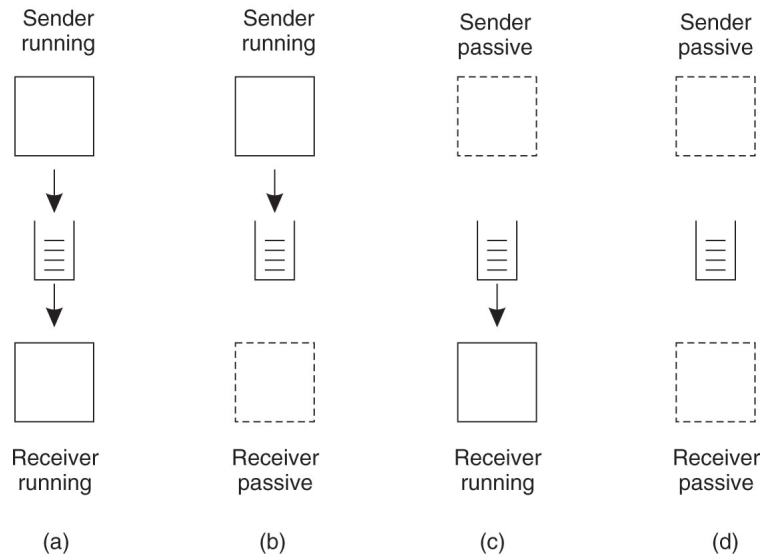

Message-Queuing Model

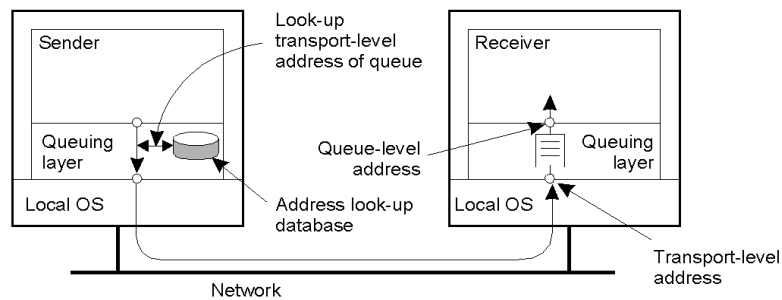

Primitive	Meaning
Put	Append a message to a specified queue
Get	Block until the specified queue is nonempty, and remove the first message
Poll	Check a specified queue for messages, and remove the first. Never block.
Notify	Install a handler to be called when a message is put into the specified queue.



General Architecture of a Message-Queuing System (2)

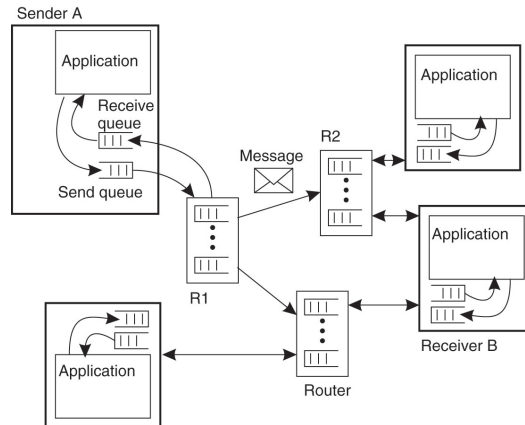

- Queue manager and relays
 - Relays use an overlay network
 - Relays know about the network topology and how to route



Message Brokers

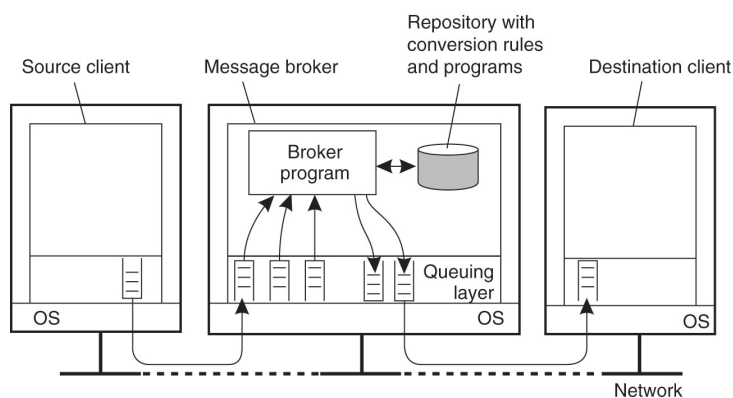

- Message broker: application level gateway in MQS
 - Convert incoming messages so that they can be understood by destination (format conversion)
 - Also used for pub-sub systems



IBM's WebSphere MQ

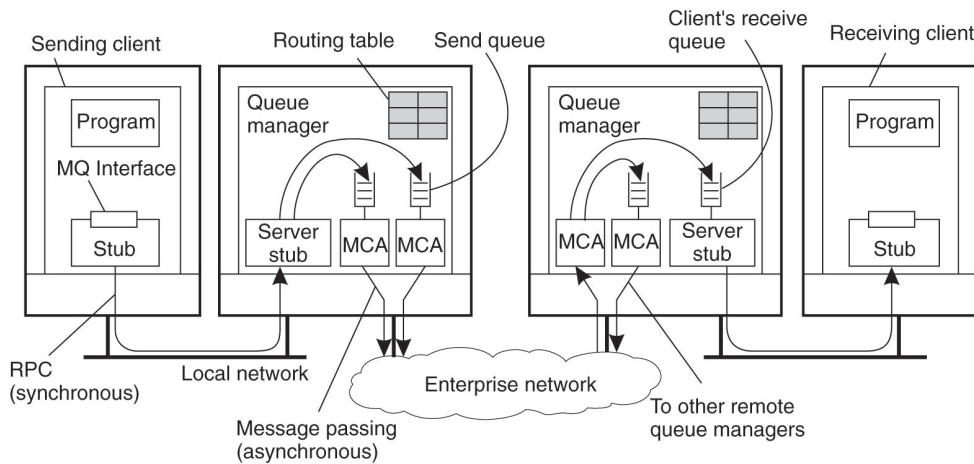

- Queue managers manage queues
 - Connected through message channels
- Message channel agent (MCA)
 - Checks queue, wraps into TCP packet, send to receiving MCA



Stream Oriented Communication

- Message-oriented communication: request-response
 - When communication occurs and speed do not affect correctness
- Timing is crucial in certain forms of communication
 - Examples: audio and video (“continuous media”)
 - 30 frames/s video => receive and display a frame every 33ms
- Characteristics
 - Isochronous communication
 - Data transfers have a maximum bound on end-end delay and jitter
 - Push mode: no explicit requests for individual data units beyond the first “play” request



Examples

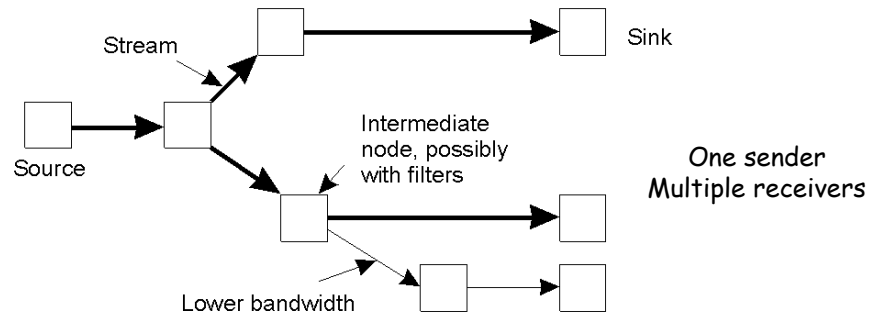
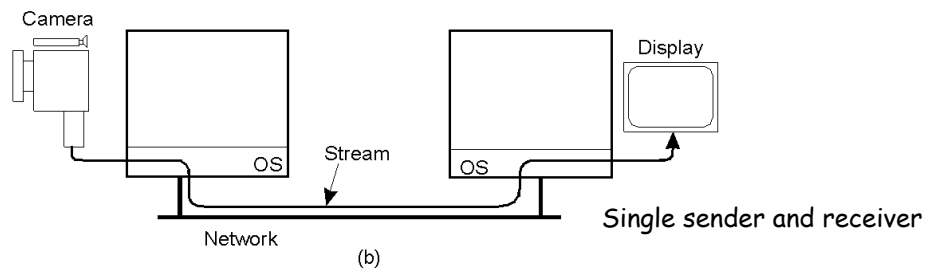

Streams and Quality of Service

- Properties for Quality of Service:
- The required bit rate at which data should be transported.
- The maximum delay until a session has been set up
- The maximum end-to-end delay .
- The maximum delay variance, or jitter.
- The maximum round-trip delay.



Quality of Service (QoS)

- Time-dependent and other requirements are specified as *quality of service (QoS)*
 - Requirements/desired guarantees from the underlying systems
 - Application specifies workload and requests a certain service quality
 - Contract between the application and the system

Characteristics of the Input	Service Required
<ul style="list-style-type: none">• maximum data unit size (bytes)• Token bucket rate (bytes/sec)• Token bucket size (bytes)• Maximum transmission rate (bytes/sec)	<ul style="list-style-type: none">• Loss sensitivity (bytes)• Loss interval (μsec)• Burst loss sensitivity (data units)• Minimum delay noticed (μsec)• Maximum delay variation (μsec)• Quality of guarantee



Specifying QoS: Token bucket

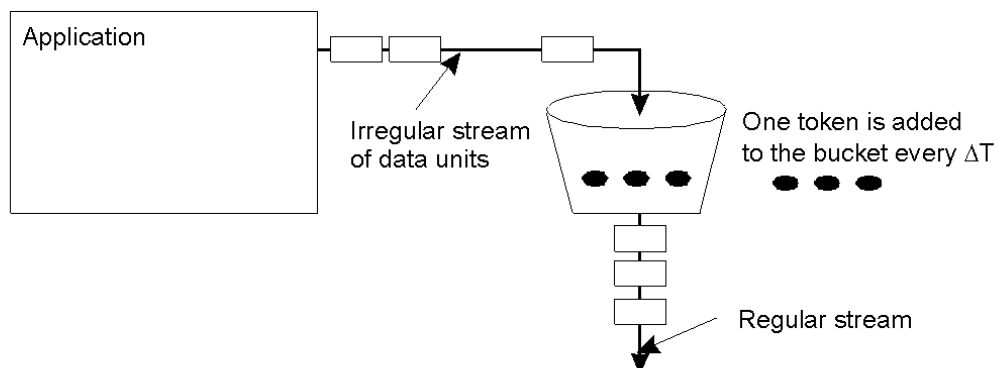

- The principle of a token bucket algorithm
 - Parameters (rate r , burst b)
 - Rate is the average rate, burst is the maximum number of packets that can arrive simultaneously



Enforcing QoS

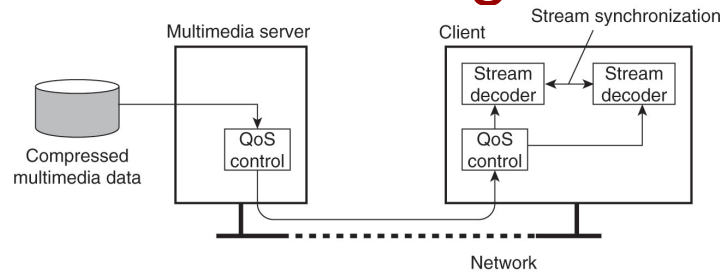

- Enforce at end-points (e.g., token bucket)
 - No network support needed
- Mark packets and use router support
 - Differentiated services: expedited & assured forwarding
- Use buffers at receiver to mask jitter
- Packet losses
 - Handle using forward error correction
 - Use interleaving to reduce impact



Enforcing QoS (1)

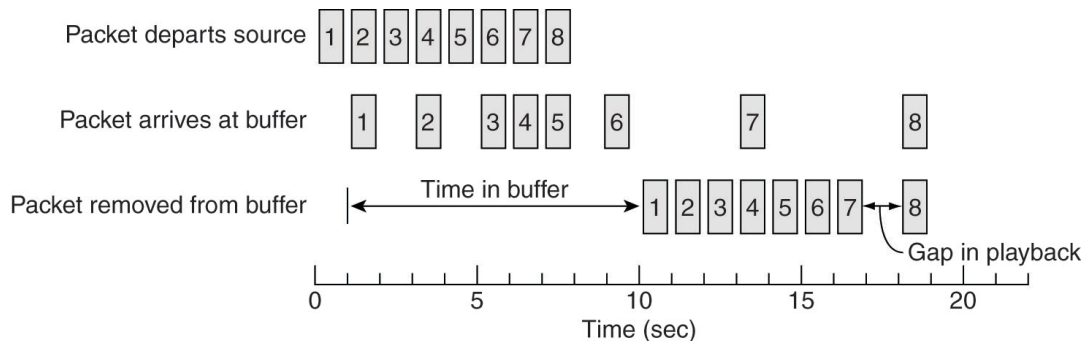

Enforcing QoS (2)

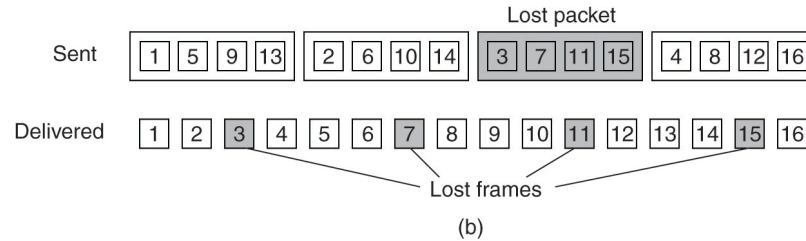
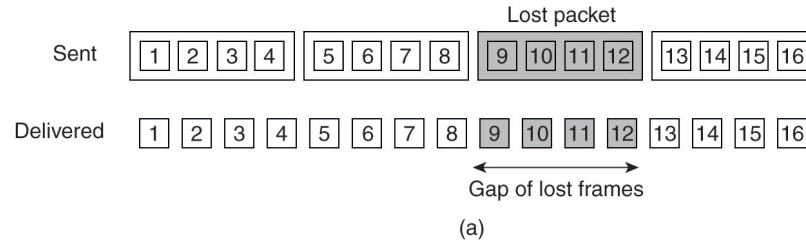

- Can also use forward error correction (FEC)



Stream synchronization

- Multiple streams:
 - Audio and video; layered video
- Need to sync prior to playback
 - Timestamp each stream and sync up data units prior to playback
- Sender or receiver?
- App does low-level sync
 - 30 fps: image every 33ms, lip-sync with audio
- Use middleware and specify playback rates



Synchronization Mechanism

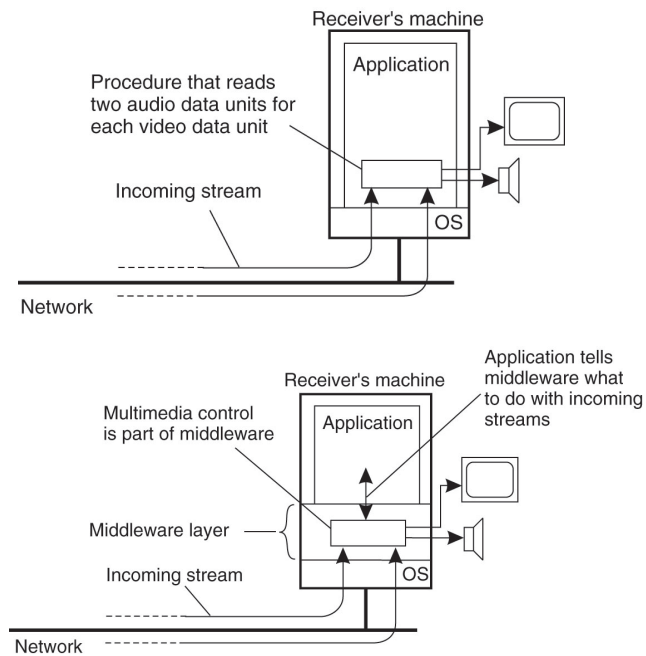

Multicasting

- Group communication
 - IP multicast versus application-level multicast
 - Construct an overlay multicast tree rooted at the sender
 - Send packet down each link in the tree
- Issues: tree construction, dynamic joins and leaves



Overlay Construction

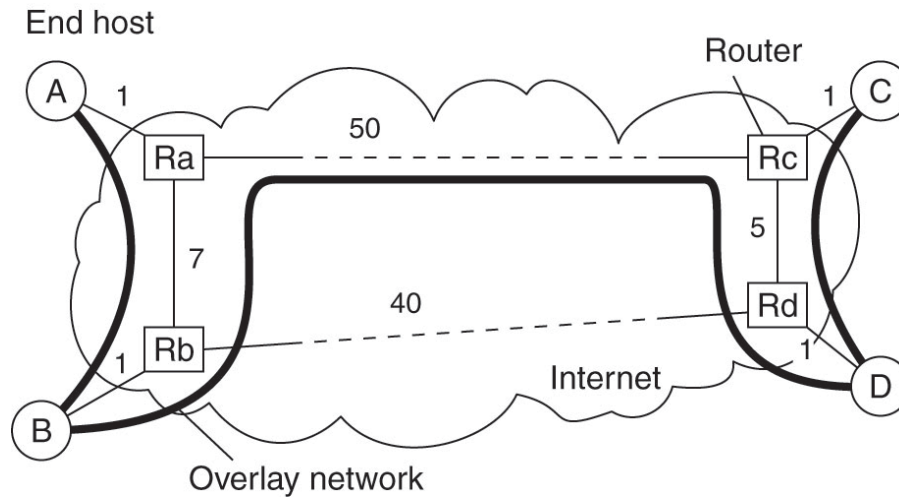

New Topic: Naming

- Names are used to share resources, uniquely identify entities and refer to locations
- Need to map from name to the entity it refers to
 - E.g., Browser access to www.cnn.com
 - Use name resolution
- Differences in naming in distributed and non-distributed systems
 - Distributed systems: naming systems is itself distributed
- How to name mobile entities?



Example: File Names

- Hierarchical directory structure (DAG)
 - Each file name is a unique path in the DAG
 - Resolution of `/home/steen/mbox` a traversal of the DAG
- File names are *human-friendly*

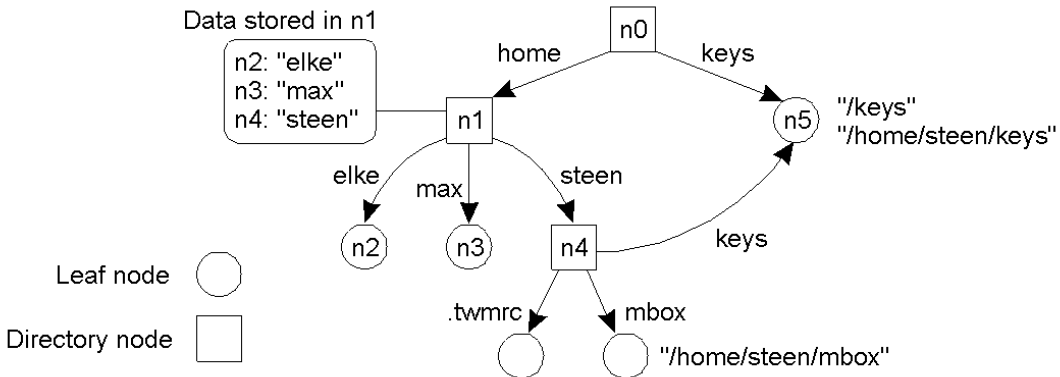

Resolving File Names across Machines

- Remote files are accessed using a node name, path name
- NFS mount protocol: map a remote node onto local DAG
 - Remote files are accessed using local names! (*location independence*)
 - OS maintains a mount table with the mappings

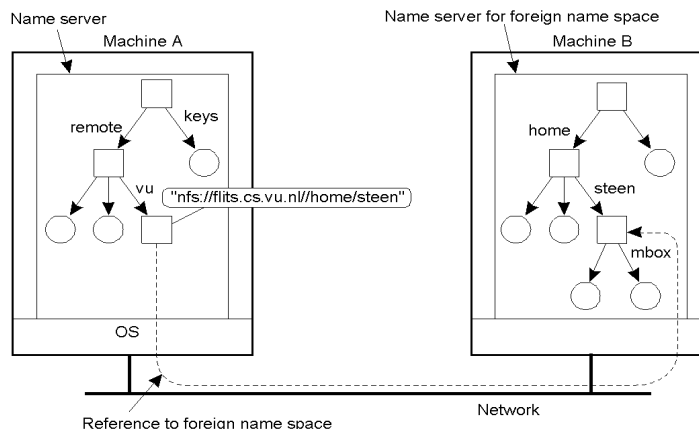

Name Space Distribution

- Naming in large distributed systems
 - System may be global in scope (e.g., Internet, WWW)
- Name space is organized hierarchically
 - Single root node (like naming files)
- Name space is distributed and has three logical layers
 - Global layer: highest level nodes (root and a few children)
 - Represent groups of organizations, rare changes
 - Administrational layer: nodes managed by a single organization
 - Typically one node per department, infrequent changes
 - Managerial layer: actual nodes
 - Frequent changes
 - Zone: part of the name space managed by a separate name server



Name Space Distribution Example

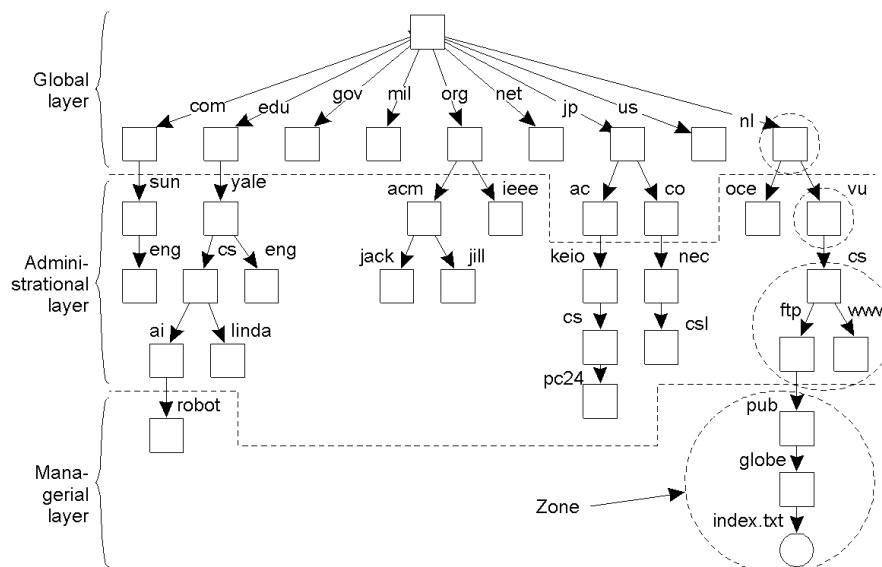

- An example partitioning of the DNS name space, including Internet-accessible files, into three layers.



Name Space Distribution

Item	Global	Administrational	Managerial
Geographical scale of network	Worldwide	Organization	Department
Total number of nodes	Few	Many	Vast numbers
Responsiveness to lookups	Seconds	Milliseconds	Immediate
Update propagation	Lazy	Immediate	Immediate
Number of replicas	Many	None or few	None
Is client-side caching applied?	Yes	Yes	Sometimes

- A comparison between name servers for implementing nodes from a large-scale name space partitioned into a global layer, as an administrative layer, and a managerial layer.
- The more stable a layer, the longer are the lookups valid (and can be cached longer)



Programming Assignment 1

- Goal: familiarity with RPCs, threads, sync, distributed application design
- Design a multi-tier micro-blogging site

